



# FÉDÉRATION INTERNATIONALE DE GYMNASTIQUE



## FIG Apparatus Norms

CIRQUE DU SOLEIL.



LONGINES®



# Official Partners of the FIG

The FIG is proud to present its Official Partners, who not only support the FIG financially and in kind, but understand Gymnastics and the importance of the FIG's efforts to promote the development of all its disciplines.

Our Official Partners help to make our World Championships and the World Gymnaestrada a great success and constantly support our member Federations.

We thank them for their dedication and ask the World of Gymnastics to return the favour by supporting the companies that advance the spirit of Gymnastics.



Janssen  
fritsen



SPIETH  
Gymnastic



PASTORELLI®

Bänfer

GYMNOVA



Taishan Sports Industry Group



Chacott



# **FÉDÉRATION INTERNATIONALE DE GYMNASTIQUE**

## **Apparatus Norms**

# GYMNOVA



[www.gymnova.com](http://www.gymnova.com)

Gymnova, supplier to  
major gymnastics competitions.

Gymnova • 45 rue Gaston de Flotte • BP 56 13375 Marseille • Cedex 12  
Tél. +33 (0)4 91 87 51 20 • Fax +33 (0)4 91 93 86 89 • [info@gymnova.com](mailto:info@gymnova.com)

## **Editorial**

In its commitment to serve its partners and performers ever better at the international competition level, the International Federation of Gymnastics (FIG) is exceptionally pleased to introduce the new edition of the *Apparatus Norms* for gymnastics. This publication is based on the revision of the 2009 edition and has been in effect since 1.1.2011.

This document is the result of a team effort led by the members of the FIG Apparatus Commission in close cooperation with the concerned Technical Committees and both the Scientific and Medical Commissions. Mr. Ludwig Schweizer of the University of Freiburg (Germany), Director of the FIG Apparatus Testing Institute has managed the editing process.

The new contents of this FIG Apparatus Manual offer a didactical approach, which allows the readers to learn about the particular functions of each apparatus and about the intricate process that surrounds certification and approval. This publication also serves as a source of official information for all National Federations and lays the foundation of the collaboration between the FIG and the apparatus manufacturers.

The new concept of these regulations' layout makes it possible to update the specific data pertaining to each apparatus used in the various gymnastic disciplines. It allows the technicians, the organizers, and above all the apparatus manufacturers to be kept abreast immediately on the latest developments in this important area. The drafting of these norms has taken into consideration our Technical Regulations, Codes of Points and Media Regulations.

With this publication, the FIG is renewing its commitment to the absolute necessity of providing standards for the apparatus used in official events and to guaranteeing that consistent testing and certification procedures are provided by fully neutral institutes delivering certificates in due form. In this respect, the FIG is pleased to further contribute to the improvement of our gymnasts' safety and to remain vigilant about fair play in competition.

We wish to thank everyone who has contributed to the publication of this document. The FIG wishes to all of them much success and a prosperous future at the service of the gymnasts and their managers.

With our compliments,

## **INTERNATIONAL FEDERATION OF GYMNASTICS**

Bruno Grandi  
*President*

André Gueisbuhler  
*Secretary General*

Atilla Örsel, President  
*Apparatus Commission*

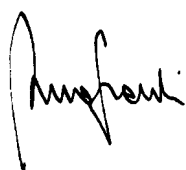

# Top equipment made in Holland!

Engineering is a skill which literally **made** Holland. Building windmills, bridges and dams made it possible to claim land from the sea on which many Dutch people live their daily lives. **Attention for detail**, solid **workmanship** and a **design** that is able to withstand the forces of nature over time are basic starting points for any Dutch engineer. It is therefore no wonder that the Gymnastic Equipment, which is designed and built by these very Dutch engineers is known world wide as well for its quality, **durability** and its **suitability** for its purpose.



Foto Erasmus Brug - UN Studie - de Pictonight - Amsterdam 2011



**janssen  
fritsen**

**Janssen-Fritsen Gymnastics b.v.**

Phone: +31 492-530930 • [export@janssen-fritsen.nl](mailto:export@janssen-fritsen.nl) • [www.janssen-fritsen.com](http://www.janssen-fritsen.com)

## **Division of chapters**

I General part

II Apparatus Norms

III Certificates and diplomas

Appendix

Impressum

IV Testing procedures

Explanations concerning the structure / systematic of the apparatus Norms FIG

II
MAG 4
01.01.2011
24

- Line 1      Number of the chapter
- Line 2      Discipline and number of apparatus
- Line 3      Date of validity
- Line 4      Page number within the chapter



# **FÉDÉRATION INTERNATIONALE DE GYMNASTIQUE**

## **I General Part**

Foto: Qingwei Chen

# QUALITY with SAFETY REQUIREMENTS

*„I trust in it“  
Elisabeth Seitz*

Elisabeth Seitz  
[www.elisabeth-seitz.de](http://www.elisabeth-seitz.de)

Fourfold German champion of all-rounder  
(asymmetric bars, balance beam and floor) at Berlin 2010

YOUR MANUFACTURER FROM THE CENTER OF GERMANY

Official Partner of



# Bänfer®



Content

I
01.01.2009
1

Page

---

1	Introduction / layout	I/2
2	Purpose and Principles	I/2
3	Validity of the Apparatus Norms	I/3
4	Guarantee for Quality	I/4

# EUROTRAMP®

## 50th Anniversary



[www.eurotramp.com](http://www.eurotramp.com)

I
01.01.2011
2

## 1. Introduction / Layout

The last edition of the Apparatus Norms dates from 2009. Since then, Gymnastics has developed, some Norms have changed, additional testing procedures were introduced and detailed for some apparatus. It was therefore essential that the Apparatus Norms 2009 had to be revised.

The FIG Apparatus Commission has decided to present the new booklet in four parts.

- PART I. is the general part and contains the aim of these Rules, the introduction, the layout and general principles.  
Part I is aimed at all users.
- PART II. contains the actual Apparatus Norms with drawings, measurements, description of functional properties and testing norms.  
Part II is also aimed at all users.
- PART III. contains the procedures for how to obtain FIG Certificates and Diplomas.  
Part III is mainly oriented to the apparatus manufacturers.
- PART IV. contains the detailed description of the testing procedures and is directed to the apparatus manufacturers and the FIG recognised Testing Institutes.

## 2. Purpose and Principles

- The purpose of these Apparatus Norms is first, to have equivalent apparatus at all competitions. It is essential for the competitors to have the same, optimal conditions for the preparations for competitions and at competitions all over the World. This is necessary for practical reasons, for competition fairness and comparison and for safety.
- All apparatus used at official FIG events; the Olympic Games and the World Games must have a valid FIG Certificate. This Certificate will be issued by the FIG, provided the apparatus has been tested successfully.
- The controlled certification by the FIG and the testing procedures guarantee, that the Apparatus Norms are respected. With the Diplomas issued by the FIG, a partnership between the FIG and the apparatus manufacturers is created.

I
01.01.2011
3

- The choice of material and construction must be left to the manufacturers, to allow the apparatus to adapt to progress, development and new construction techniques. Therefore the FIG only prescribes measurements, functional properties, norms for testing and testing procedures.
- The FIG recognises neutral Testing Institutes, which have to follow the testing procedures decided by the FIG to test the functional properties, the norms and measurements of the apparatus.
- The testing procedures must be constantly developed with the purpose to have meaningful testing procedures for all apparatus and further develop existing procedures. It is important to develop testing procedures which guarantee, that the apparatus fulfil the norms also after intensive use.
- To enforce the Apparatus Norms and to guarantee the quality of apparatus after intensive use, the FIG may, before, during or after an event, control the apparatus and make re-tests at the Testing Institute.
- In case of contradictions between the Apparatus Norms and the Code of Points, the Apparatus Norms prevail.

### **3. Validity of the Apparatus Norms FIG Certificate compulsory for all Apparatus**

These Apparatus Norms were decided by the FIG Executive Committee at its meeting on October 28<sup>th</sup> 2010 and are valid as of 1st January 2011.

They replace all previous editions as well as all previous decisions and publications regarding apparatus norms from the Executive Committee, Technical Committees and the Apparatus Commission of the FIG.

They are compulsory for all FIG events, as well as at the Olympic Games, World Games, Commonwealth Games, Asian Games, Pan-American Games, University Games and other multi-sport Games with International participation. At all those events, no apparatus which does not have a valid FIG Certificate may be used.

The FIG strongly recommends that at all other national and international events, organised independently by its member federations or unions, only apparatus which have a valid FIG Certificate may be used.

At international events, apparatus without a valid FIG Certificate may only be used provided all participating member federations have agreed in writing and bear the full responsibility and liability for the use of such uncertified apparatus. The FIG waives all responsibility in the cases where apparatus without a valid FIG Certificate are used.

I
01.01.2011
4

#### **4. Guarantee for quality**

To guarantee equal quality and fairness for the competitors and to guarantee their safety and health, testing procedures for the quality of apparatus are necessary. Those testing procedures are defined in the Apparatus Norms part II and IV.

**These apparatus norms as well as the requested norms and functional properties must not only be fulfilled at the time of the test at the Testing Institute. The apparatus manufacturers must guarantee to produce their apparatus in such a quality that the apparatus also fulfil the requested norms, functional properties and safety aspects after intensive use e.g. after a World Championship.**

Official Supplier of 43rd Artistic Gymnastics  
World Championships *2011 in TOKYO*  
東京

Official FIG Partner

 **Senoh**

Always the Best Quality to your Best Performance

**Senoh Corporation**

250 Matsuhidai, Matsudo, Chiba 270-2214, JAPAN  
Tel: +81-47-386-5807 Fax: +81-47-385-5196  
Web: <http://www.senoh.co.jp/english/>  
E-Mail: [intl-1@senoh.co.jp](mailto:intl-1@senoh.co.jp)





# **FÉDÉRATION INTERNATIONALE DE GYMNASTIQUE**

## **II Apparatus Norms**

II
01.01.2011
1

1.	Overview of the apparatus for the FIG disciplines	II/3
1.1	MAG Men's artistic gymnastics	
1.2	WAG Women's artistic gymnastics	
1.3	RG Rhythmic gymnastics	
1.4	AER Aerobic gymnastics	
1.5	TRA Trampoline gymnastics	
1.6	ACRO Acrobatic gymnastics	
2.	Apparatus for the FIG disciplines, Construction and material description, dimensions	
2.1	Men's artistic gymnastics	II/10
	MAG 1 Floor	
	MAG 2 Pommel horse	
	MAG 3 Rings	
	MAG 4 Vaulting table	
	MAG 5 Parallel bars	
	MAG 6 Horizontal bar	
	MAG 11 Landing mat 20 cm	
	MAG 12 Landing mat 10 cm (Pommel horse)	
	MAG 13 Supplementary mat 10 cm	
	MAG 14 Vaulting Board	
	MAG 15 Vaulting Board safety collar (Round off vaults)	
	MAG 16 Mat for hands (vault)	
2.2	Women's artistic gymnastics	II/40
	WAG 1 Vaulting table	
	WAG 2 Uneven bars	
	WAG 3 Balance beam	
	WAG 4 Floor	
	WAG 11 Landing mat 20cm	
	WAG 13 Supplementary mat 10cm	
	WAG 14 Vaulting Board	
	WAG 15 Vaulting Board safety collar (Round off vaults)	
	WAG 16 Mat for hands (vault)	

II
01.01.2011
2

		Page
2.3	Rhythmic gymnastics	II/63
	RG 1 Floor	
	RG 2 Rope	
	RG 3 Hoop	
	RG 4 Ball	
	RG 5 Club	
	RG 6 Ribbon	
	RG 10 Measurement Table	
2.4	Aerobic gymnastics	II/71
	AER 1 Floor	
2.5	Trampoline Gymnastics	II/75
	TRA 1 Trampoline	
	TRA 2 Double Mini Trampoline	
	TRA 3 Tumbling Track	
	TRA 11 Landing mat 30cm for DMT, TUM; Safety mat 20cm for TRA, DMT	
	TRA 12 Spotter mat for TRA, DMT	
	TRA 13 Supplementary mat for TUM	
	TRA 14 Vaulting board, Tumbling	
	TRA 15 Time measurement device for TRA	
2.6	Acrobatic Gymnastics	II/95
	ACRO 1 Floor	
	ACRO 11 Landing mat	
3.	Surfaces of apparatus, safety zones, total surfaces	II/99
4.	Competition area	II/101
5.	Required Equipment for FIG - Competitions	II/107
6.	Training centres, Auxiliary apparatus for training	II/111
7.	Development of apparatus / tests	II/113
8.	Information regarding the apparatus used in general gymnastics	II/115





II
01.01.2009
3

1 Overview of the apparatus  
of the FIG disciplines

# 1 MENS' ARTISTIC GYMNASTICS MAG



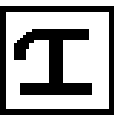



II
MAG
01.01.2009
4

Number	Apparatus	Pictogram	Description Construction Material	Test	
				Institute	Competition
<b>APPARATUS</b>					
MAG1	Floor		II MAG1	IV MAG1	yes
MAG2	Pommel horse		II MAG2	IV MAG2	yes
MAG3	Rings		II MAG3	IV MAG3	yes
MAG4	Vaulting table		II MAG4	IV MAG4	yes
MAG5	Parallel bars		II MAG5	IV MAG5	yes
MAG6	Horizontal bar		II MAG6	IV MAG6	yes
<b>SUPPLEMENTARY APPARATUS</b>					
MAG11	Landing mat 20cm		II MAG11	IV MAG11	yes
MAG12	Landing mat 10cm		II MAG12	IV MAG12	yes
MAG13	Supplementary mat 10cm		II MAG13		yes
MAG14	Vaulting board		II MAG14	IV MAG14	yes
MAG15	Vaulting Board safety collar (Round off vaults)		II MAG15		yes
MAG16	Mat for hands (vault)		II MAG16		yes

## 2 WOMENS' ARTISTIC GYMNASTICS WAG

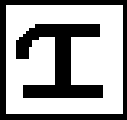

II
WAG
01.01.2009
5

Number	Apparatus	Pictogram	Description Construction Material	Test	
				Institute	Competition
<b>APPARATUS</b>					
WAG1	Vaulting table		II WAG1	IV WAG1	yes
WAG2	Uneven bars		II WAG2	IV WAG2	yes
WAG3	Balance beam		II WAG3	IV WAG3	yes
WAG4	Floor		II WAG4	IV WAG4	yes
<b>SUPPLEMENTARY APPARATUS</b>					
WAG11	Landing mat 20cm		II WAG11	IV WAG11	yes
WAG13	Supplementary mat 10cm		II WAG13		yes
WAG14	Vaulting board		II WAG14	IV WAG14	yes
WAG15	Vaulting Board safety collar (Round off vaults)		II WAG15		yes
WAG16	Mat for hands (vault)		II WAG16		yes



II
RG
01.01.2011
6

### 3 RHYTHMIC GYMNASTICS RG

Number	Apparatus	Pictogram	Description Construction Material	Test	
				Institute	Competition
RG1	Floor		II RG1	IV RG1	yes

Number	Apparatus	Pictogram	Description- Construction Material	Test	
				By TC/ par CT	Competition
<b>APPARATUS</b>					
RG2	Rope		II RG2	yes*	yes*
RG3	Hoop		II RG3	yes*	yes*
RG4	Ball		II RG4	yes*	yes*
RG5	Clubs		II RG5	yes*	yes*
RG6	Ribbon		II RG6	yes*	yes*
RG10	Measurement Table with Balance		II RG10	Institute	

\* Test with measuring table according to the directives of the competition



II
AER
01.01.2009
7

## 4 AEROBIC GYMNASTICS AER

Number	Apparatus	Pictogram	Description Construction Material	Test	
				Institute	Competition
<b>APPARATUS</b>					
AER1	Floor		II AER1	IV AER1	yes

## 5 TRAMPOLINE GYMNASTICS TRA



II
TRA
01.01.2011
8

Number	Apparatus	Description- Construction Material	Test	
			Institute	Competition
<b>APPARATUS</b>				
TRA1	Trampoline	II TRA1	IV TRA1	yes
TRA2	Double Mini- Trampoline	II TRA2		yes
TRA3	Tumbling track	II TRA3	IV TRA3	yes
<b>SUPPLEMENTARY APPARATUS</b>				
TRA 11	Landing mat 30cm for DMT, TUM; Safety mat for TRA, DMT (20 cm)	II TRA11	IV TRA11	yes
TRA 12	Spotter mat Trampoline Gymnastics DMT	II TRA12		yes
TRA 13	Supplementary mat 10cm for TUM	II TRA13		yes
TRA 14	Vaulting board Tumbling	II TRA14	IV TRA14	yes
TRA 15	Time measurement device for Trampoline competitions (TMD)	II TRA15	IV TRA15	yes

# 6 ACROBATIC GYMNASTICS ACRO



II
ACRO
01.01.2009
9

Number	Apparatus	Pictogram	Description Construction Material	Test	
				Institute	Competition
<b>APPARATUS</b>					
ACRO1	Floor		II ACRO1	IV ACRO1	yes
<b>SUPPLEMENTARY APPARATUS</b>					
ACRO11	Landing mat 20 cm		II ACRO11	IV ACRO11	yes

II
01.01.2009
10

2 Apparatus of the FIG disciplines  
Construction and material description,  
dimensions



2.1 MAG Men's artistic gymnastics

II
MAG 1
01.01.2009
11

Floor

Use • Men's Artistic Gymnastics

Construction / Description of material, measurements

Form	<p>The Performance Area shall have a square format. The surface must be horizontal, even and without gaps</p> <p>Border :</p> <p>Horizontal and even, at the same height as the Performance area</p> <p>Border's variant :</p> <p>Width 50 cm, horizontal and even, at the same height as the Performance area, additional 50 cm inclination border, slope may not exceed 25 %.</p> <p>Safety zone:</p> <p>The safety zone shall be kept totally free as a surrounding zone around the performance area and the border. It shall be horizontal, even and without gaps.</p>																
Measurements	<table border="0"> <tr> <td>Performance area</td> <td>1200 cm x 1200 cm Tolerance +/- 3 cm</td> </tr> <tr> <td>Diagonals of the performance area:</td> <td>1697 cm +/- 5cm</td> </tr> <tr> <td>Border</td> <td>100 cm, min.</td> </tr> <tr> <td>Border as a variant</td> <td></td> </tr> <tr> <td>Horizontal Area, Width</td> <td>50 cm, min.</td> </tr> <tr> <td>Slope max. 25 %, Width</td> <td>50 cm, min.</td> </tr> <tr> <td>Height of outer border at the very end</td> <td>3,5 cm, max.</td> </tr> </table> <p>When there is a delimitation strip between the Performance area and the border :</p> <table border="0"> <tr> <td>Delimitation strip width</td> <td>5 cm, Tolerance +/- 0,5 cm</td> </tr> </table> <p>The delimitation strip is part of the Performance area.</p>	Performance area	1200 cm x 1200 cm Tolerance +/- 3 cm	Diagonals of the performance area:	1697 cm +/- 5cm	Border	100 cm, min.	Border as a variant		Horizontal Area, Width	50 cm, min.	Slope max. 25 %, Width	50 cm, min.	Height of outer border at the very end	3,5 cm, max.	Delimitation strip width	5 cm, Tolerance +/- 0,5 cm
Performance area	1200 cm x 1200 cm Tolerance +/- 3 cm																
Diagonals of the performance area:	1697 cm +/- 5cm																
Border	100 cm, min.																
Border as a variant																	
Horizontal Area, Width	50 cm, min.																
Slope max. 25 %, Width	50 cm, min.																
Height of outer border at the very end	3,5 cm, max.																
Delimitation strip width	5 cm, Tolerance +/- 0,5 cm																
Functional Properties	<p>Performance area and border</p> <ul style="list-style-type: none"> <li>- Equal elasticity on the surface as well as dampening.</li> <li>- When in use it should not have any hindering motion energy</li> <li>- Elasticity and dampening must be balanced in such a way that they guarantee the gymnast stability and freedom of movement. It must not restrict turns and slide movements.</li> <li>- The surface cover of the Performance area must provide a balance between anti-skid and slippage. It must not cause skin burns.</li> <li>- The floor must not produce disturbing sound during the execution of an exercise. It must assure a low noise level.</li> </ul>																
Colours	<p>Of plain colour which choice is left to the manufacturer's discretion. For certain events the FIG may stipulate the colours. The delimitation shall have a clear contrast to the performance area.</p>																

Norms / Functional properties  
Regarding tests carried out by FIG Tests Institutes : please see chapter IV

<b>II</b>
<b>MAG 1</b>
<b>01.01.2009</b>
<b>12</b>

**Floor**

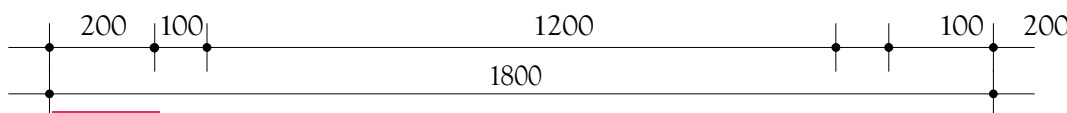
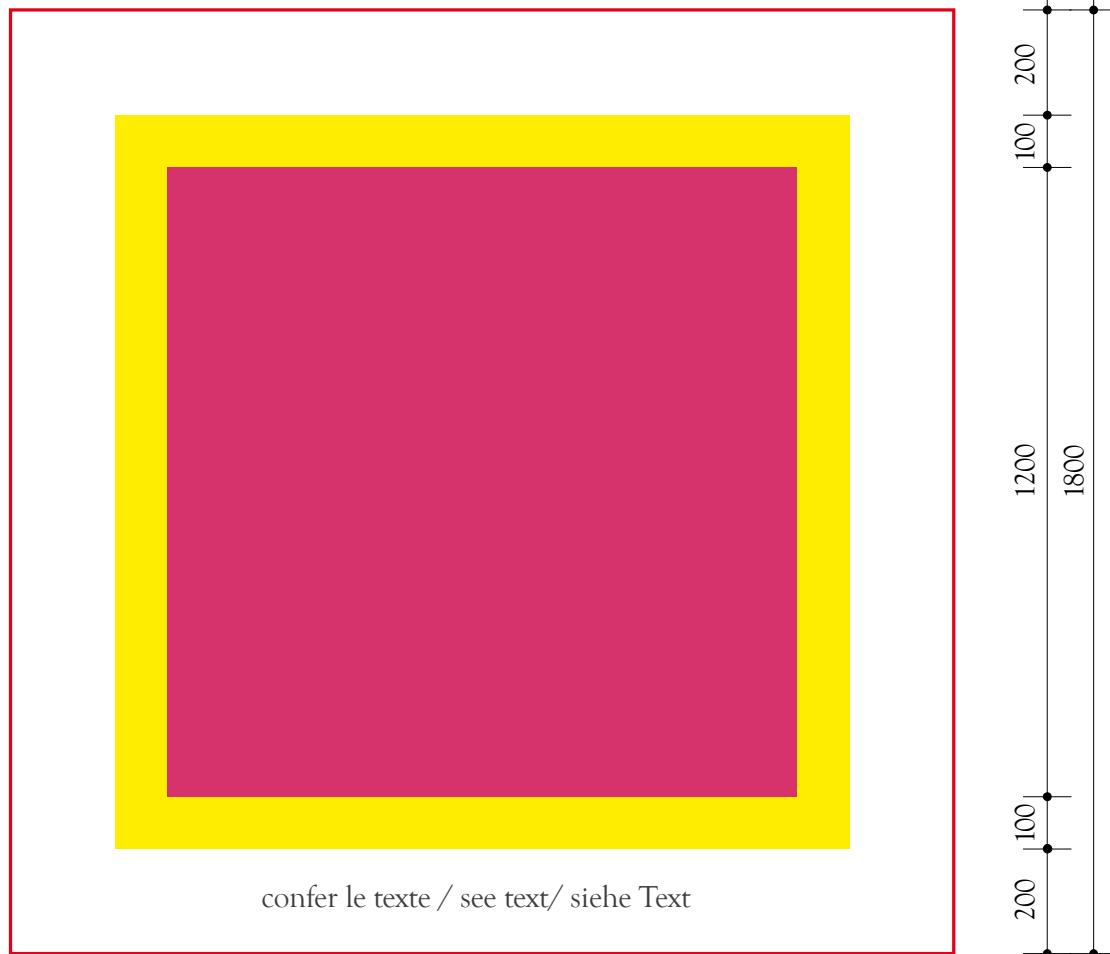

- surface de compétition, arena, Wettkampffläche
- cadre, edge, Umrandung
- zone de sécurité, safety zone, Sicherheitszone

variantes, profile - variants, Schnitt - Varianten A, B, C

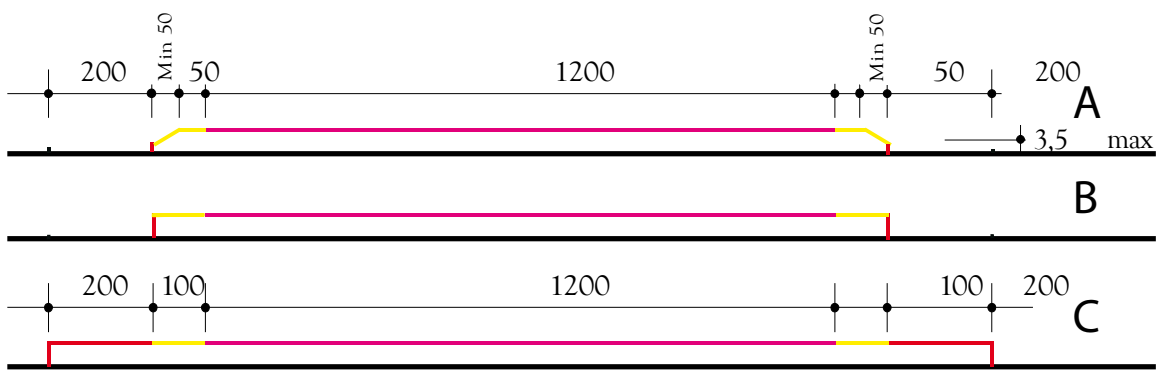

<b>II</b>
<b>MAG 2</b>
<b>01.01.2009</b>
<b>13</b>

## Pommel Horse

Use Men's Artistic Gymnastics

### Construction / Description of material, measurements

#### Form

The apparatus consists of a prismoid body which is placed horizontally onto a base. On the upper surface of the body, two pommels are attached crossways.

#### The Horse Body :

Its sides - viewed from the two length and two front sides - slant inward.

In cross section the upper surface shows an arch, in length section, it is horizontal, and even, and without gaps, except for the points of attachments.

All corners and edges are rounded.

#### The Pommels:

They are circular in profile, rise from their bases and then make a slight circular transition to the horizontal.

The base which serves as a support conforms to arched upper surface of the horse body.

#### The Base :

Forms and conception do not have any prescriptions.

It must assure stability of the body and the horizontal position of its length and cross axis; all technical safety rules must be observed.

#### Measurements

			Tolerance:	
Body :	Length at top	160 cm	* 1 cm/ <sup>1</sup>	
	Length at bottom	155 cm	* 1 cm/ <sup>2</sup>	
	Width at top	35 cm	* 1 cm/ <sup>1</sup>	
	Width at bottom	30 cm	* 1 cm/ <sup>2</sup>	
	Height	28 cm	* 1 cm	
	Height from upper surface to the floor:	115 cm	* 1 cm	
	Pommels:	Inner vertical diameter	≥ 7 cm	
		Width at base	31 cm	* 0,2 cm
		Height	12 cm	* 0,5 cm
		Profile diameter (at the nearly horizontal part)	3,4 cm	* 0,1 cm
Span of the nearly Horizontal part		15 cm	* 0,2 cm	
Distance between Pommels:				
	Minimum	≤ 40 cm		
	Maximum	≥ 45 cm		

\* refers to the tolerance, +/-,

<b>II</b>
<b>MAG 2</b>
<b>01.01.2009</b>
<b>14</b>

## Pommel Horse

### Functional Properties

$l^1$  and  $l^2$  are measurements linked to each other. In case of variation, they must move in the same direction, e.g. if width at top is 355 mm, the width at the bottom must be  $305 \pm 10$  mm.

#### Adjustments :

**Pommels**      The distance between the two pommels, inside measurement, must be continuously adjustable from 40 cm to 45 cm.

#### Body :

Its support area must be elastic and absorbing.

The side surfaces, as well as corners and edges must have a dampening effect.

Indentations caused by support may not hinder turns of the palms.

The tear proof cover material, which tightly covers the body, may not slip or wrinkle.

The upper surface must offer the ability to glide, but not be slippery.

The cover material must be moisture absorbing and not cause skin burns.

The vertical and cross axis of the horse must be horizontal. During use, the horse must remain static.

#### Pommels :

In principle, they are made of stiff materials.

A slight flexibility, which must not affect support stability, is provided by the padded upper surface of the body.

The anchoring to the body must assure immobility.

The upper surface is slip proof, but must allow the palms to turn and slide in support.

The pommels must be moisture absorbent and neutral to the use of magnesia.

#### Base :

It must allow exact levelling of the body, and assure its immobility.

Floor anchoring for stabilization purposes is permitted, as well as anti-skid, dampening floor covering.

With exception of parts on the floor (feet) the base may not protrude from the body of the horse. The height of the feet must allow an even, horizontal mat covering.

<b>II</b>
<b>MAG 2</b>
<b>01.01.2009</b>
<b>15</b>

## Pommel Horse

### Colours

No parts of the base may show sharp corners or edges, nor rough surfaces.

Since the body is attached to the base, the stability of the apparatus depends on it as well. This is also one of the most important requirements for safety.

- Are left to the manufacturer's discretion
- For certain events the FIG may choose the colour.
  
- Based on practical tests and considered allowed are :
- For the body : The natural colour of leather, even when synthetic materials are used for the revetment
- For the pommel : Natural wood colour, or a light neutral shade, if synthetic materials are used
- For the base : Varnished colour

### Mats

- The mats used for pommel horse must have a height of 10cm (MAG 11/12)

Norms / Functional properties  
Regarding tests carried out by FIG Tests Institutes : please see chapter IV

II
MAG 2
01.01.2009
16

# Pommel Horse

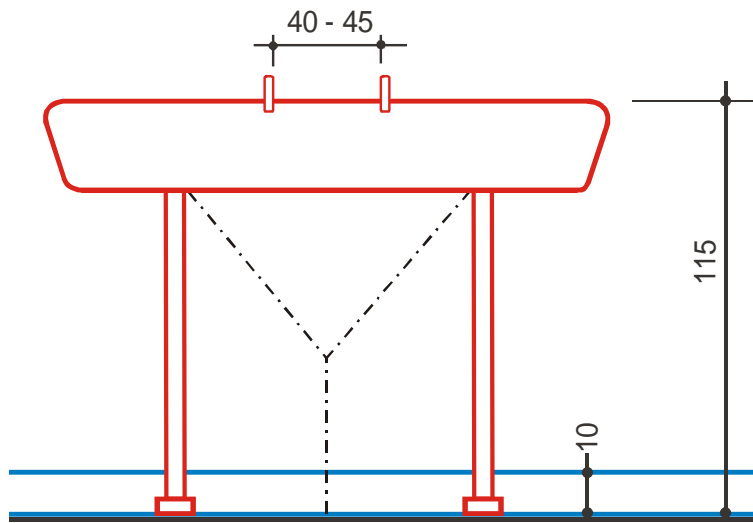

vue de côté  
side view  
Ansicht Längsseite

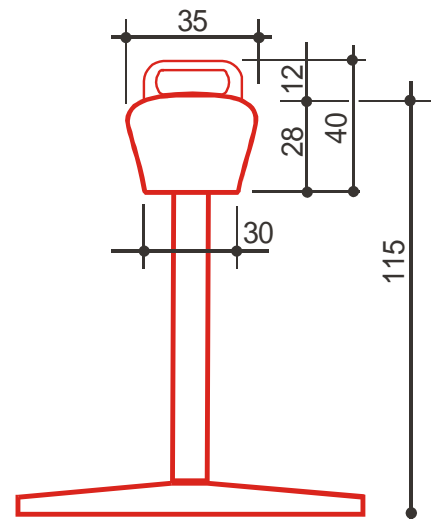

vue de face  
front view  
Ansicht Stirnseite

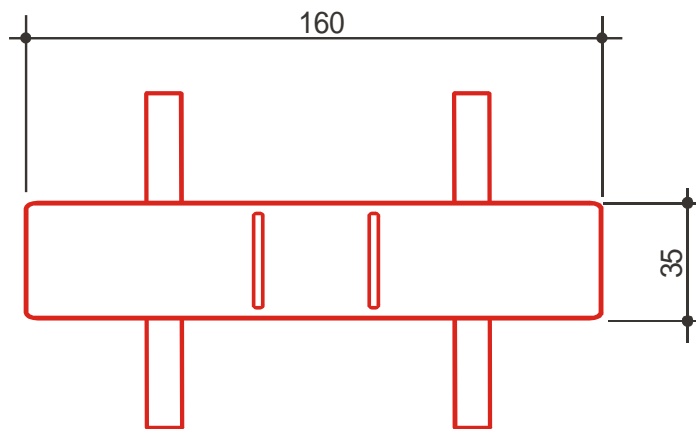

vue de dessus  
top view  
Aufsicht

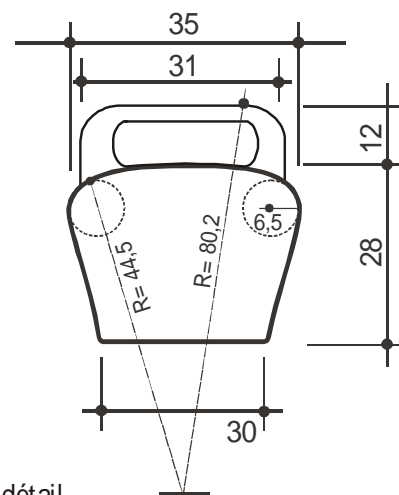
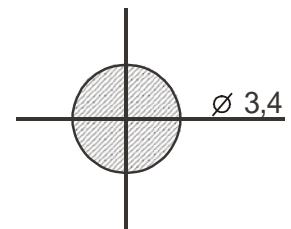

détail  
detail  
Detail

cotes obligatoires;  
construction selon le gré;  
dessin en exemple

dimensions: mandatory;  
design: at your discretion;  
drawing: typical example

Maße bindend;  
Konstruktion freigestellt;  
Zeichnung als Beispiel

II
MAG 3
01.01.2006
17

## Rings

Use • Men's Artistic Gymnastics

### Construction / Description of material, measurements

Form	<p>The apparatus consists of two circular rings, attached to cables suspended on a frame.</p> <p>The rings have a uniform, circular profile.</p> <p>The cables have a pivoting mechanism at their suspension point on the frame. In the still position, the cables must hang in the vertical.</p> <p>The frames consist of two supports and a horizontal beam which contains the attachment devices of the cables.</p> <p>The frame is held upright by four tension cables, anchored to the floor. (Max. Ø 1 cm).</p> <p>To distribute the pressure, the supports have widened floor plates.</p>																																																																																		
Measurements	<table border="0"> <tr> <td colspan="4">Rings:</td> </tr> <tr> <td>Inner diameter</td> <td>18 cm</td> <td></td> <td>* 0,1 cm</td> </tr> <tr> <td>Diameter of profile</td> <td>2,8 cm</td> <td></td> <td>* 0,1 cm</td> </tr> <tr> <td colspan="4">Pendulum length below suspension device:</td> </tr> <tr> <td>Distance from point of attachment to Lower inner side of the rings</td> <td>300 cm</td> <td></td> <td>* 1 cm</td> </tr> <tr> <td>Distance of lower inner side of the rings :</td> <td></td> <td></td> <td></td> </tr> <tr> <td>- to floor</td> <td>280 cm</td> <td></td> <td>* 0,5 cm</td> </tr> <tr> <td>Straps :</td> <td></td> <td></td> <td></td> </tr> <tr> <td>- Length</td> <td>70 cm</td> <td></td> <td>* 1 cm</td> </tr> <tr> <td>- Width</td> <td>4 cm</td> <td></td> <td>* 1 cm</td> </tr> <tr> <td>Distance between the 2 points of attachment on the frame</td> <td>50 cm</td> <td></td> <td>* 0,5 cm</td> </tr> <tr> <td colspan="4">Frame:</td> </tr> <tr> <td>Height of attachment point at horizontal beam: - to the floor</td> <td>580 cm</td> <td></td> <td>* 1 cm</td> </tr> <tr> <td>Inner Distance of supports on the floor</td> <td>260 cm</td> <td></td> <td>min</td> </tr> <tr> <td>At height of 320 cm (point of indentation)</td> <td>280 cm</td> <td></td> <td>min</td> </tr> <tr> <td>Length of horizontal beam</td> <td>120 cm</td> <td></td> <td>min</td> </tr> <tr> <td>Measured 30cm under the attachment point</td> <td></td> <td></td> <td></td> </tr> <tr> <td colspan="4">Distance of tension cables :</td> </tr> <tr> <td>- in vertical direction of apparatus</td> <td>550 cm</td> <td></td> <td>* 5 cm</td> </tr> <tr> <td>- in cross section to apparatus</td> <td>400 cm</td> <td></td> <td>* 5 cm</td> </tr> </table> <p>* Tolerance, +/-</p>			Rings:				Inner diameter	18 cm		* 0,1 cm	Diameter of profile	2,8 cm		* 0,1 cm	Pendulum length below suspension device:				Distance from point of attachment to Lower inner side of the rings	300 cm		* 1 cm	Distance of lower inner side of the rings :				- to floor	280 cm		* 0,5 cm	Straps :				- Length	70 cm		* 1 cm	- Width	4 cm		* 1 cm	Distance between the 2 points of attachment on the frame	50 cm		* 0,5 cm	Frame:				Height of attachment point at horizontal beam: - to the floor	580 cm		* 1 cm	Inner Distance of supports on the floor	260 cm		min	At height of 320 cm (point of indentation)	280 cm		min	Length of horizontal beam	120 cm		min	Measured 30cm under the attachment point				Distance of tension cables :				- in vertical direction of apparatus	550 cm		* 5 cm	- in cross section to apparatus	400 cm		* 5 cm
Rings:																																																																																			
Inner diameter	18 cm		* 0,1 cm																																																																																
Diameter of profile	2,8 cm		* 0,1 cm																																																																																
Pendulum length below suspension device:																																																																																			
Distance from point of attachment to Lower inner side of the rings	300 cm		* 1 cm																																																																																
Distance of lower inner side of the rings :																																																																																			
- to floor	280 cm		* 0,5 cm																																																																																
Straps :																																																																																			
- Length	70 cm		* 1 cm																																																																																
- Width	4 cm		* 1 cm																																																																																
Distance between the 2 points of attachment on the frame	50 cm		* 0,5 cm																																																																																
Frame:																																																																																			
Height of attachment point at horizontal beam: - to the floor	580 cm		* 1 cm																																																																																
Inner Distance of supports on the floor	260 cm		min																																																																																
At height of 320 cm (point of indentation)	280 cm		min																																																																																
Length of horizontal beam	120 cm		min																																																																																
Measured 30cm under the attachment point																																																																																			
Distance of tension cables :																																																																																			
- in vertical direction of apparatus	550 cm		* 5 cm																																																																																
- in cross section to apparatus	400 cm		* 5 cm																																																																																

<b>II</b>
<b>MAG 3</b>
<b>01.01.2006</b>
<b>18</b>

## Rings

### Functional Properties

The suspension device and the rings must be able to swing out freely in all directions. With the exception, of course, of the cable's direction.

Even submitted to tension, the rings must rotate easily. For this purpose, the pivoting device exists.

Under load both rings shall have the same height above the ground.

The rings must guarantee a sure grip and therefore must not be slippery. The rings must absorb moisture.

The rings as such are made of a stiff material; in effect however, the apparatus must have a certain elasticity, to protect the gymnast's joints. This is done partly through form and the method by which the frame is held, and can be helped by an elastic dampening device on the suspension cables.

This device however may not produce springy or counter swings.

Rings are either made of wood or synthetic material.

Except for sanding, the rings' upper surfaces receive no other treatment. The material must remain natural in order to absorb magnesia and moisture so as to assure a sure grip.

The pivoting mechanism, the elastic dampening device and the stepless height regulator are connected to the hanging points.

The cables are protected by a smooth synthetic cover material.

The straps, to which the rings are attached, are made of leather or of a sturdy equivalent material.

Aside from the required resistance of materials, the stability of the apparatus must be assured.

During the exercise, the frame and the suspension device must not move or cause hindering sways or vibrations.

The required elasticity of the suspension device must not produce springy or counter swings.

Sharp corners and edges and rough surfaces are to be avoided.

### Colour

The rings retain the natural colour of the material.

Norms / Functional properties  
Regarding tests carried out by FIG Tests Institutes : please see chapter IV

# Rings

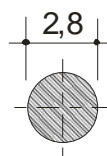
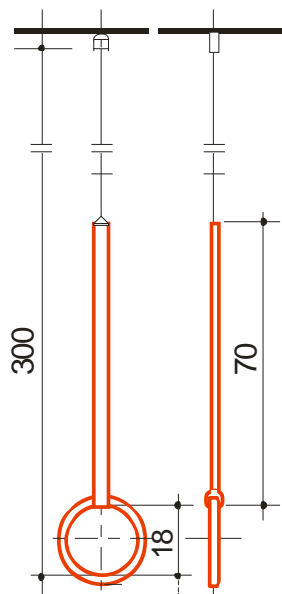
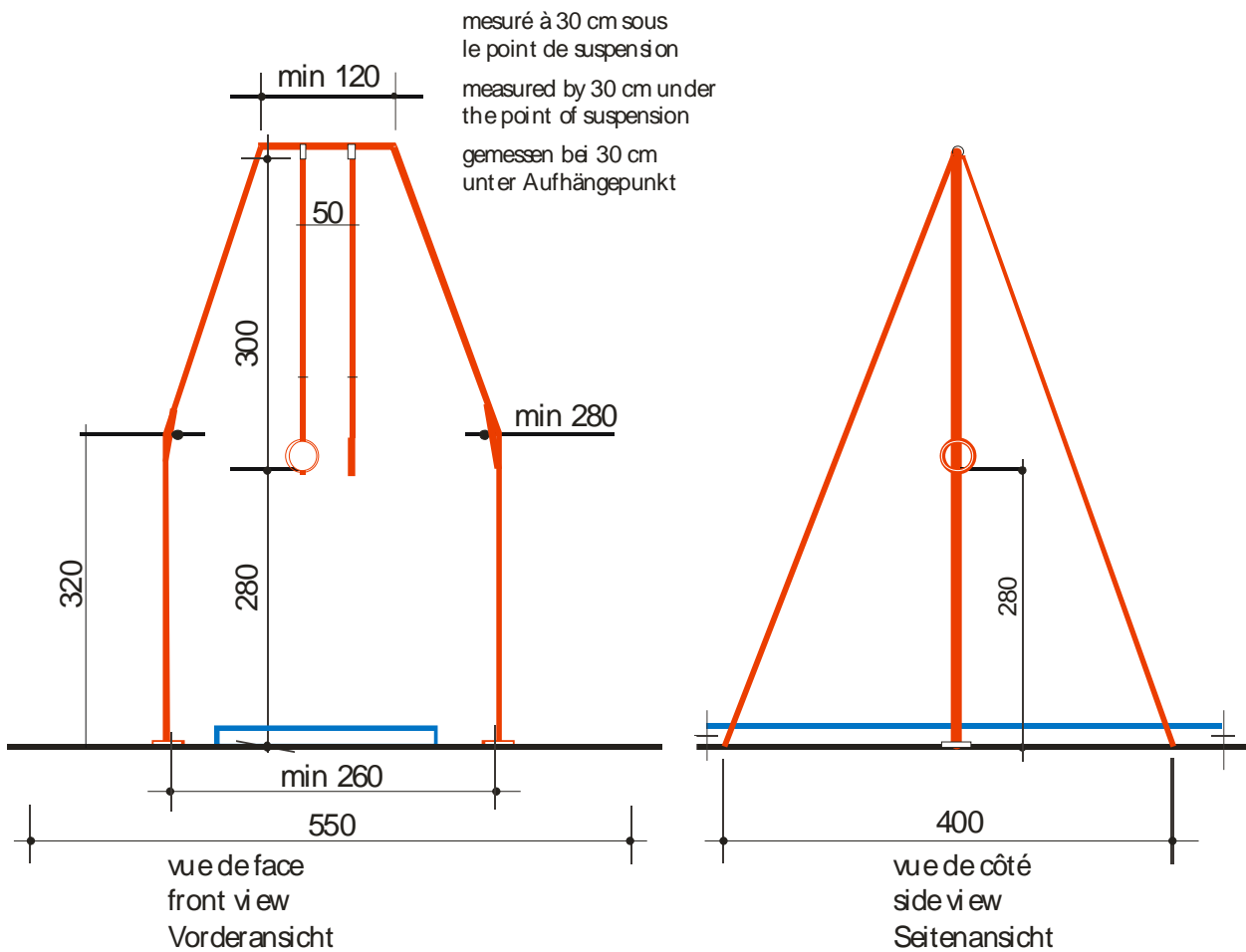

cotes obligatoires;  
construction selon le gré;  
dessin en exemple

dimensions: mandatory;  
design: at your discretion;  
drawing: typical example

Maße bindend;  
Konstruktion freigestellt;  
Zeichnung als Beispiel

<b>II</b>
<b>MAG 4</b>
01.01.2011
<b>20</b>

## Vaulting table

Use • Men's Artistic Gymnastics

### Construction / Description of material, measurements

#### Form

The apparatus consists of a slightly inclined table body which is mounted onto a "monostand" bottom frame. The table body consists of a front surface (A) which, seen from the direction of the vault, is inclined to 8° to the vertical and merges into two arched bends (B1 and B2) and then into a linear cover surface (C) which is inclined 3° to the horizontal. The table body is divided into a bounce area (A) and a push away area (B and C) with a clear colour contrast. The different surfaces merge into each other without any gaps in between. The push away area is slightly rounded in transversal direction (D).

All corners and edges are rounded. The bottom frame must offer the table body a stable and secure supporting surface and must guarantee the abundance by the technical safety regulations. The bottom frame with cushioning may not present any parts that protrude from under the vaulting table's body except on the landing side. As a collision protection dangerous metal parts of the support must be cushioned.

Recommendation: All levers and locking mechanisms should be incorporated into the under construction.

At the landing side the legs of the bottom frame must be cushioned at the same height level as the landing mat (20cm, tolerance +10cm).

The vaulting table including the cushioning of the bottom frame must represent a "monostand" - construction.

#### Measurements

Table body:	length:	120 cm	+/- 1 cm
	width:	95 cm	+/- 1 cm

Height at the given measurement point (see drawing) )<sup>1</sup>: 135 cm +/- 1cm

Upper height at the bounce area (see drawing) )<sup>1</sup>: 122 cm +/- 1 cm

Remark: For competitions the vaulting table must be positioned on a rigid board which has the same height as the run up area (see below)

)<sup>1</sup>: In competitions the apparatus height must correspond to the top level of the run up area.

Maximal orthogonal deviations from the given profile lines in longitudinal and transversal directions: < 1 cm

Protrusion of the leg construction below the table body on the landing side (only allowed with appropriate cut-outs in the landing mat):

15 cm maximal

Height of the leg frame 8 cm maximal

Circumference of the (cushioned) bottom frame including all levers and fixation devices between the height of 50 cm up to 85 cm

1828mm maximal

Distance between the (cushioned) leg construction including all levers and fixation devices and the projection of the table body on all four sides between the height of 50 cm up to 85 cm 25 cm minimal

The adjusted height of the vaulting table must be clearly signed at the side.

<b>II</b>
<b>MAG 4</b>
01.01.2011
<b>21</b>

## Vaulting table

Functional Properties	<p>Additional Measurements see drawing. The profile lines towards A, B1, B2 and D are to be respected as indicated in the drawing. Maximum deviations &lt; 1 cm – measured at a right angle to the profile line.</p> <p>The push away area must be shock-absorbing so that shoulders and wrists are protected.</p> <p>The rebound properties must be guaranteed to be as homogeneously as possible for all the possible impact points on the table body.</p> <p>Extended time-shift for rebounding energy at the impact points caused by extreme deflections is not acceptable.</p> <p>The table body must be evenly cushioned over the entire push away area.</p> <p>The cover material must be non-slippery but not rough. It may not cause a burning sensation on sliding.</p> <p>The bounce area must be cushioned with a high-quality material in order to provide a good collision protection.</p> <p>Recommendation: Any protruding items covered by the cushioning of the stand should be avoided or sufficiently covered to prevent perforation through the cushioning during accidental impact.</p> <p>In order to avoid swaying, vibrations and shifting, the apparatus must have a device for fastening it to the floor.</p>
Colour	<p>The colour of the surface material may be chosen according to taste. For certain events the colour may be determined by the FIG.</p>
Run up area	<p>The run-up area is composed of a run-up mat and a rigid board underneath the vaulting board.</p> <p>length (measured from the vertical projection of the beginning of the vaulting table – see “reference point” in the drawing) 2500 + 10 cm</p> <p>The start of the run-up (2500 cm) shall be marked.</p> <p>width (run-up mat) 100 +/- 1 cm</p> <p>width (rigid board underneath) 100cm min</p> <p>height (same height for run-up mat and board underneath) max 2,5 cm</p> <p>length of the rigid board underneath the vaulting board 320 +/- 1 cm</p> <p>The colour of the run-up area must have a clear contrast to the colour of the vaulting board. The whole run up area (run-up mat and the rigid board underneath) shall have the same colour.</p>
Authorized Landing zone	<p>Marking on the supplementary mat above the landing mat (see drawing).</p> <p>Width of the landing corridor at the table site: 95 cm</p> <p>Width of the landing corridor (end of 600 cm landing mat): 150 cm</p> <p>When the authorized landing zone is marked out by stripes:</p> <p>Marking strip width on the supplementary mat: 5 cm +/-0.5 cm</p> <p>The marking strip is part of the authorized landing zone.</p> <p>Additional marking strip width in the centre of the landing corridor (see drawing): 5 cm +/-0.5 cm</p> <p><i>Remarks concerning the drawings:</i></p> <ul style="list-style-type: none"> <li>- Bottom frame construction schematized.</li> <li>- All dimensions in cm</li> <li>- Tolerances for all dimensions: +/- 1cm</li> <li>- Maximal Orthogonal Deviations from the given profiles in longitudinal and transversal directions: &lt;1 cm</li> </ul> <p>Dimensions binding; Construction may be different– drawing as example.</p>

Norms / Functional properties  
Regarding tests carried out by FIG Tests Institutes : please see chapter IV

# Vaulting table

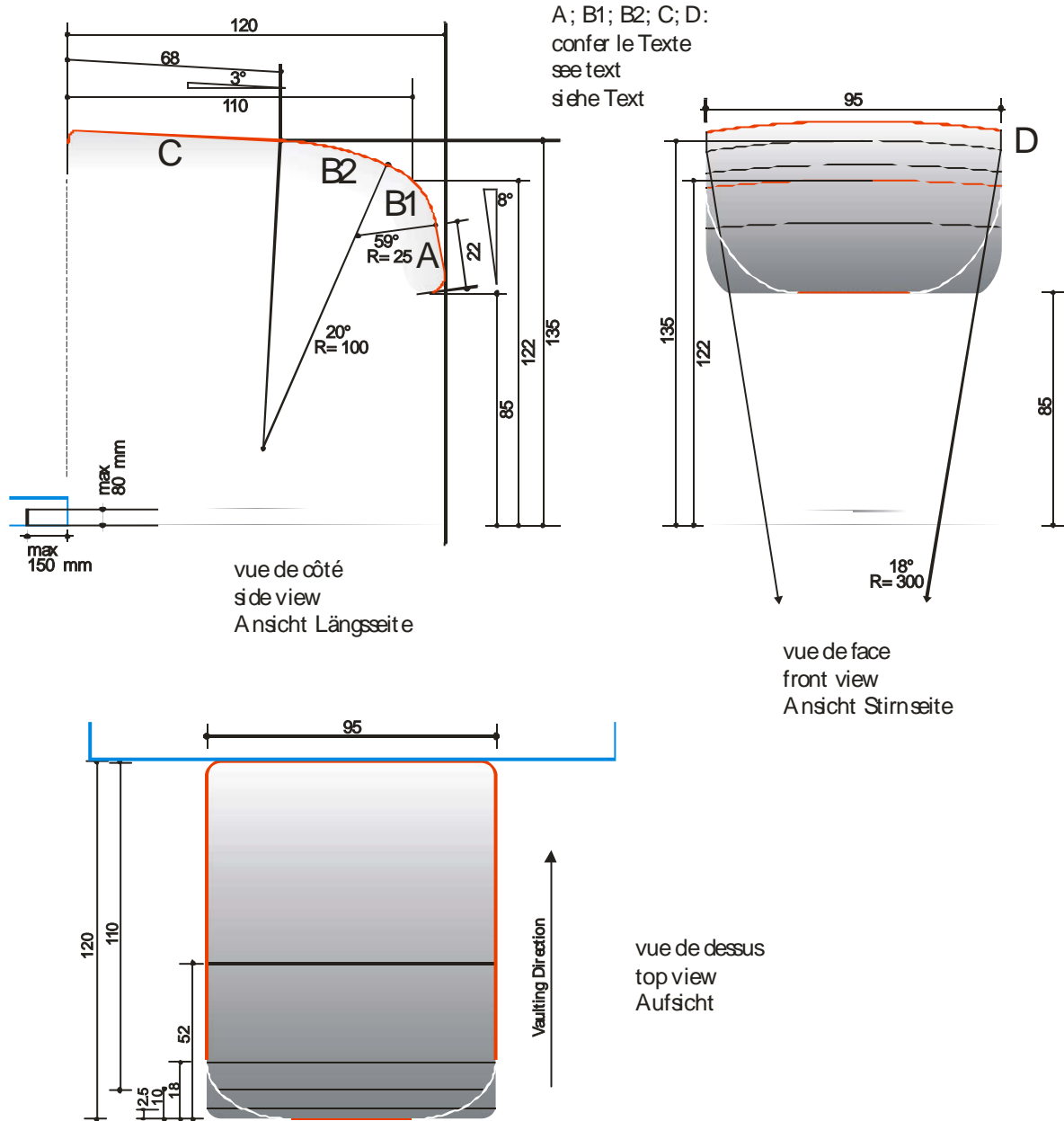

cotes obligatoires;  
construction selon le gré;  
dessin en exemple

dimensions: mandatory;  
design: at your discretion;  
drawing: typical example

Maße bindend;  
Konstruktion freigestellt;  
Zeichnung als Beispiel

<b>II</b>
<b>MAG 4</b>
01.01.2011
<b>23</b>

## Vaulting table

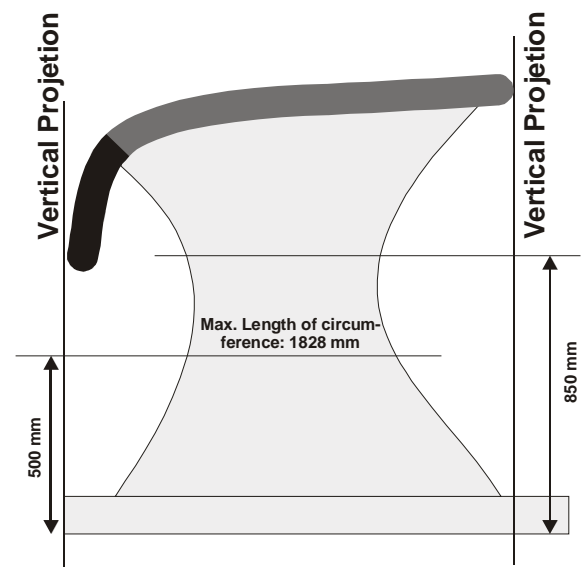
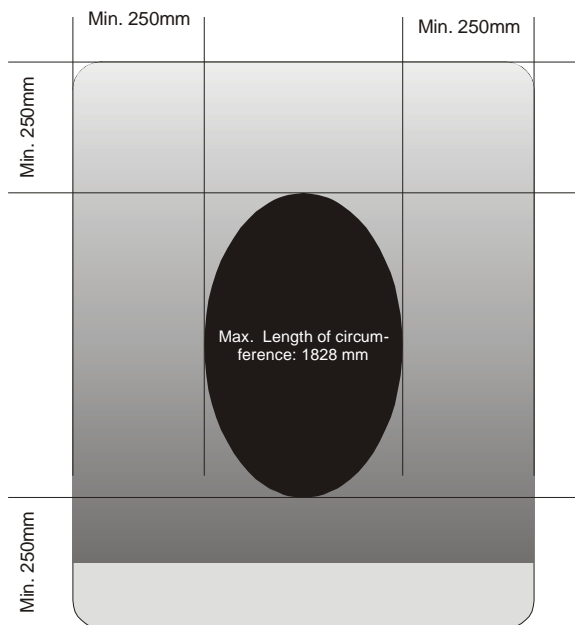

cotes obligatoires;  
 construction selon le gré;  
 dessin en exemple

dimensions: mandatory;  
 design: at your discretion;  
 drawing: typical example

Maße bindend;  
 Konstruktion freigestellt;  
 Zeichnung als Beispiel

# Vaulting table

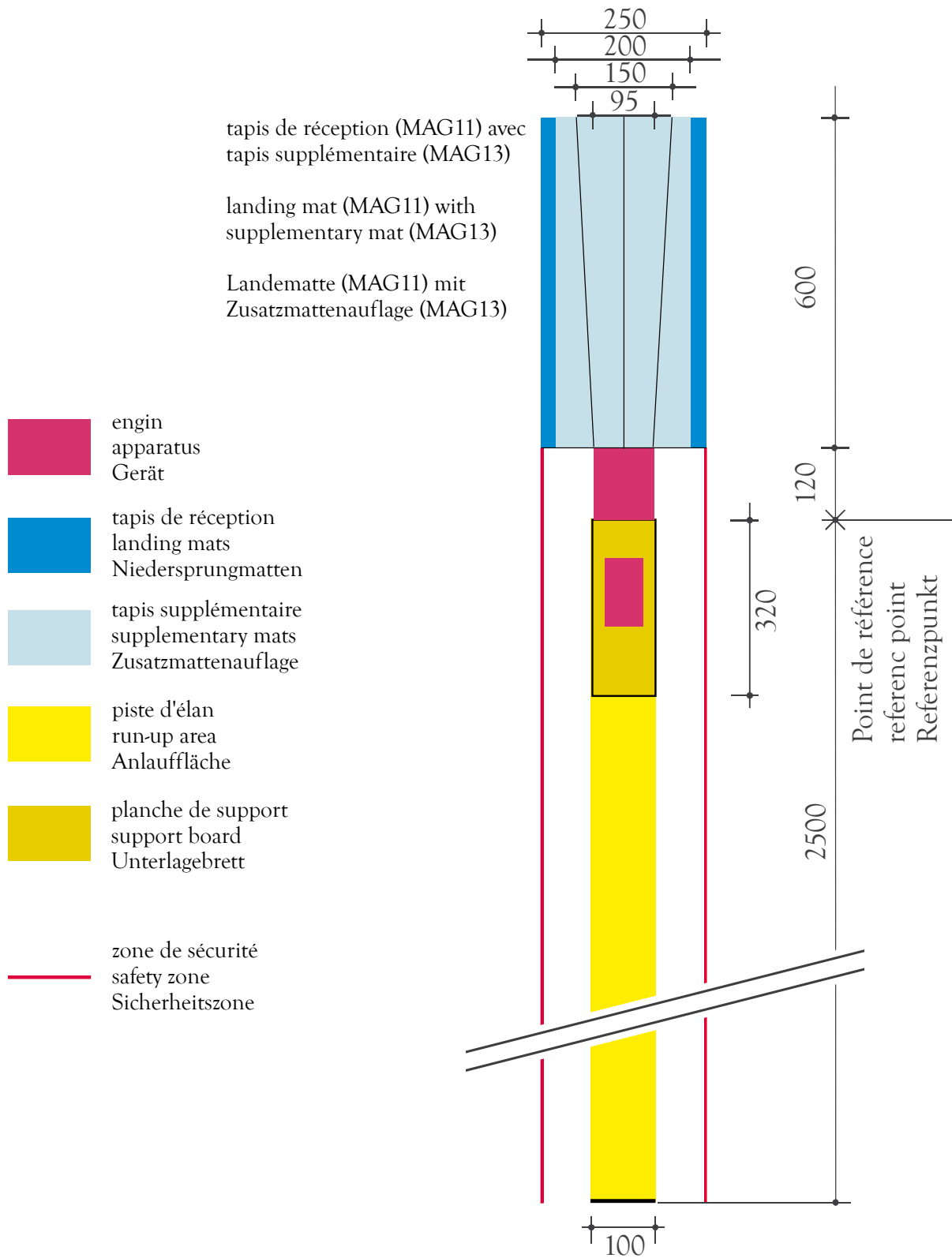

<b>II</b>
<b>MAG 5</b>
01.01.2011
<b>25</b>

## Parallel Bars

Use • Men's Artistic Gymnastics

### Construction / Description of material, measurements

#### Form

The apparatus consists of two bars of equal dimensions, which run parallel and at the same height.

The position of the bars is parallel, pre-stressing is allowed.

Each bar is supported by two upright supports, which stand on a stable base frame.

The uprights consist of a static and mobile part, that allow the height and width adjustment of the bars.

In cross section, bars present a drop like profile, which remains unchanged for their entire length.

#### Measurements

Bars :

Length	350 cm	* 1 cm
Vertical axis of profile	5 cm	* 1 mm
Horizontal axis of profile	4 cm	* 1 mm
Height of upper edge measured from the floor near to the supports	200 cm	* 1 cm
Distance between points of attachment	230 cm	* 1 cm
Distance between bars from	42 cm	
to	52 cm	

Distance between the columns at adjustment levels, min. 48 cm

Heights of mats 20 cm \* 1 cm

\* Tolerance +/-

Width adjustment: continuous adjustment of the distance between bars from at least 42 cm to 52 cm must be possible.

#### Functional Properties

The bars must have elasticity.

To assure the efficiency of this elasticity the fixing points of the bars on the uprights must be articulated.

No significant swaying of bars in the longitudinal and transversal sense must occur.

The entire apparatus must be stable. Incident vertical and transversal forces must not move the apparatus.

The upper surface of the bars must be hygroscopic, and not be slippery.

<b>II</b>
<b>MAG 5</b>
01.01.2011
<b>26</b>

## Parallel Bars

The upper surface of the bars must be made of wood, free of errors (knots, fissure, etc.). Except for sanding, it receives no other treatment.

The core may be made of wood or of another material.

The rails must be secured against breaking through.

The apparatus must not have sharp corners or edges or any protruding parts.

Rough surfaces are to be avoided.

The adjustment screws must be warranted against unintended adjustments.

The adjustment devices must be double locked to assure that they do not cede during use.

The base girders as well as the space between them must be covered by mats. They must be even and without gaps and of the same height as the surrounding mats, forming a uniform surface, from which only the uprights rise.

## Colours

The rails retain the natural wood colour.

Norms / Functional properties  
Regarding tests carried out by FIG Tests Institutes : please see chapter IV

II
MAG 5
01.01.2011
27

# Parallel Bars

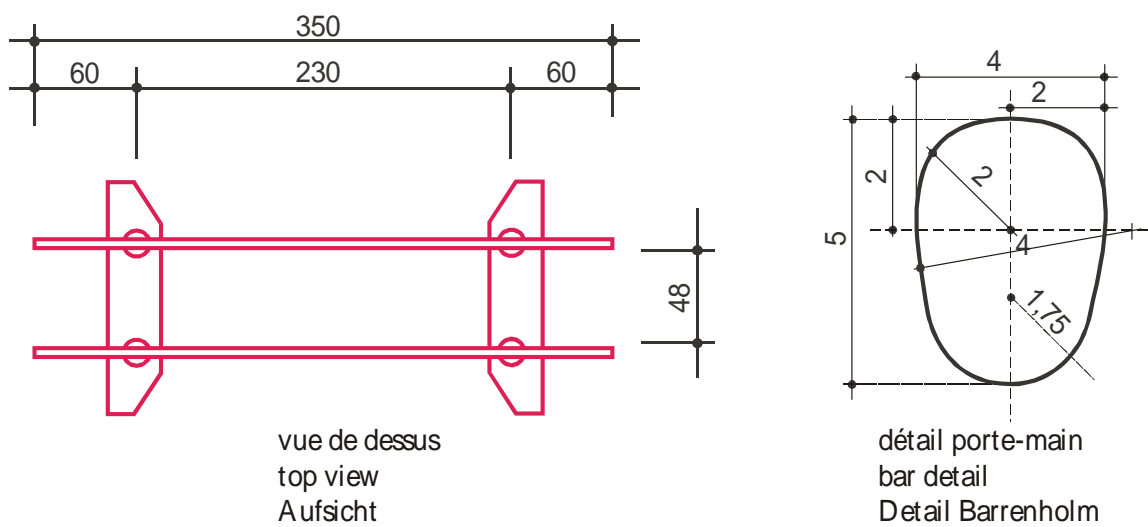
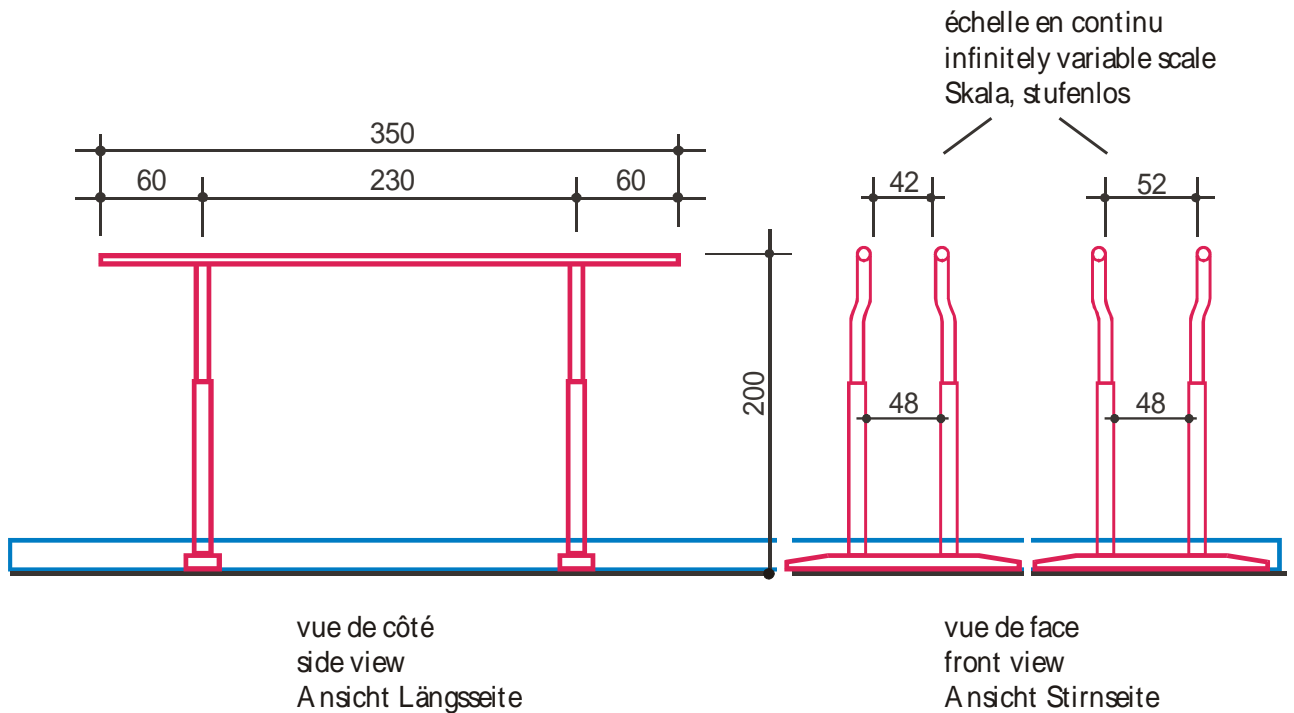

cotes obligatoires;  
construction selon le gré;  
dessin en exemple

dimensions: mandatory;  
design: at your discretion;  
drawing: typical example

Maße bindend;  
Konstruktion freigestellt;  
Zeichnung als Beispiel

<b>II</b>
<b>MAG 6</b>
<b>01.01.2009</b>
<b>28</b>

## Horizontal bar

Use • Men's Artistic Gymnastics

### Construction / Description of material, measurements

Form	<p>The Horizontal bar consists of a round bar with a constant diameter, which is held horizontally by two supports.</p> <p>The supports stand erect on the floor and have additional floor plates for displacing force.</p> <p>They are held upright by tension cables (<math>\varnothing</math> max. 1 cm), connected to four floor anchors.</p>																								
Measurements	<p>Horizontal bar :</p> <table border="0"> <tr> <td>Diameter</td> <td style="text-align: right;">2,8 cm</td> <td style="text-align: right;">* 0,01 cm</td> </tr> <tr> <td>Length between attachment points</td> <td style="text-align: right;">240 cm</td> <td style="text-align: right;">* 1 cm</td> </tr> <tr> <td>Distance between the sockets</td> <td style="text-align: right;">min 200 cm</td> <td style="text-align: right;">* 1 cm</td> </tr> <tr> <td>Height of upper edge :</td> <td></td> <td></td> </tr> <tr> <td>- measured from floor</td> <td style="text-align: right;">280 cm</td> <td style="text-align: right;">* 1 cm</td> </tr> <tr> <td>Distance of floor anchors :</td> <td></td> <td></td> </tr> <tr> <td>- Lengthwise</td> <td style="text-align: right;">550 cm</td> <td style="text-align: right;">* 5 cm</td> </tr> <tr> <td>- Crosswise</td> <td style="text-align: right;">400 cm</td> <td style="text-align: right;">* 5 cm</td> </tr> </table> <p>* Tolerance +/-</p>	Diameter	2,8 cm	* 0,01 cm	Length between attachment points	240 cm	* 1 cm	Distance between the sockets	min 200 cm	* 1 cm	Height of upper edge :			- measured from floor	280 cm	* 1 cm	Distance of floor anchors :			- Lengthwise	550 cm	* 5 cm	- Crosswise	400 cm	* 5 cm
Diameter	2,8 cm	* 0,01 cm																							
Length between attachment points	240 cm	* 1 cm																							
Distance between the sockets	min 200 cm	* 1 cm																							
Height of upper edge :																									
- measured from floor	280 cm	* 1 cm																							
Distance of floor anchors :																									
- Lengthwise	550 cm	* 5 cm																							
- Crosswise	400 cm	* 5 cm																							
Functional Properties	<p>Adjustments :</p> <p>The height adjustment must be possible to increase the height by 5 cm.</p> <p>The horizontal Bar must be elastic, and be secured against breaking through.</p> <p>The elasticity is not just determined by the bar but also by the apparatus, acting as a whole. That is why the placement of the floor anchors, the supports and the tension cables, as well as the degree of tension must be strictly observed to insure uniform elasticity.</p> <p>The bars attachment to the uprights must be articulated, to assure the effectiveness of its elasticity.</p> <p>The bar must allow turn and glide movements without slipping.</p> <p>The apparatus must be stable. The supports must not move or sway during use.</p>																								

<b>II</b>
<b>MAG 6</b>
<b>01.01.2009</b>
<b>29</b>

## Horizontal bar

---

### Colours

Neither the bar nor the tension cables should produce disturbing sounds during use.

Preferably such materials should be used which guarantee a slim form and should not block the view.

The bar retains the colour of natural polished steel.

Colours or designs of the remaining parts are left to the discretion of the manufacturer. The FIG may designate the colour for specific events.

Norms / Functional properties  
Regarding tests carried out by FIG Tests Institutes : please see chapter IV

II
MAG 6
01.01.2009
30

# Horizontal bar

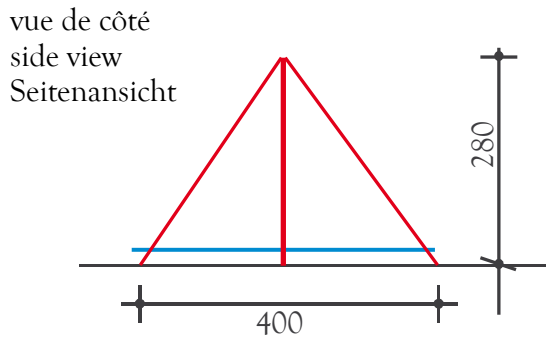
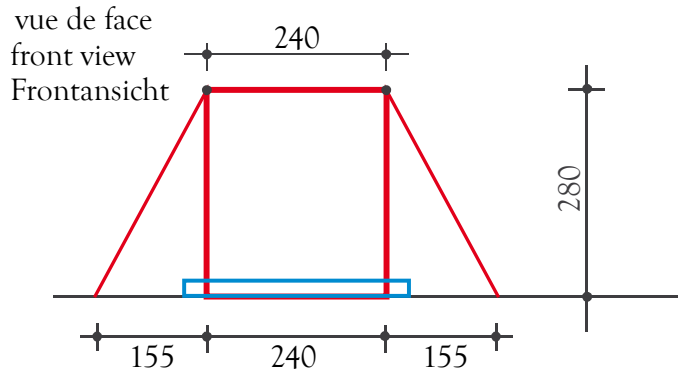

point de mesure pour différents systèmes  
de fixation de la barre  
measurement point with variants of supports  
Meßstelle bei Varianten von Reckauflagen

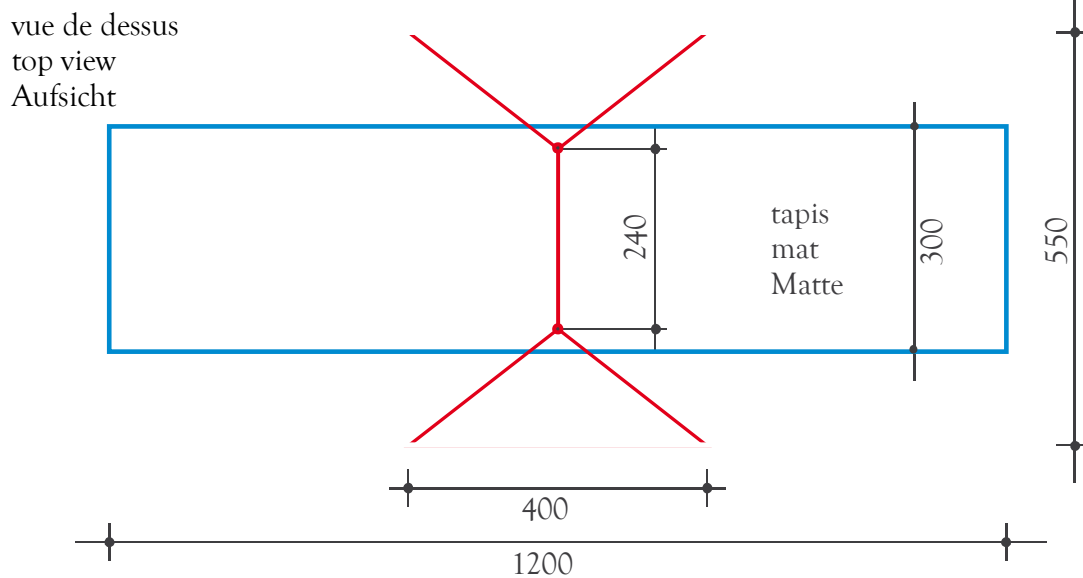
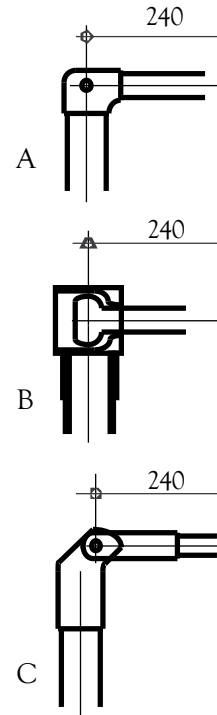

surface d'appui 550 x 1200  
floor area for apparatus 550 x 1200  
Gerätstellfläche 550 x 1200

cotes obligatoires;  
construction selon le gré;  
dessin en exemple

dimensions: mandatory;  
design: at your discretion;  
drawing: typical example

Maße bindend;  
Konstruktion freigestellt;  
Zeichnung als Beispiel

<b>II</b>
<b>MAG 11/12</b>
<b>01.01.2009</b>
<b>31</b>

## Landing mats

Use • Men's Artistic Gymnastics

### Construction / Description of material, measurements

Form	<p>Their upper surface must be horizontal, even and without gaps.</p> <p>Specially designed mats must be used to cover the basis of the apparatus evenly.</p>
Measurements	<p>Height of the landing mats (MAG 3, 4, 5, 6):      20 cm      * 1 cm</p> <p>Height of the landing mats pommel horse (MAG 2):      10 cm      * 1 cm</p> <p>* Tolerance +/-</p> <p>lengths and widths see drawing</p>
Functional Properties	<p><b>Absorbency :</b> Mats must absorb motion energy in order to reduce the reaction transmitted to the body of the landing gymnast to a tolerable proportion.</p> <p>They must respond to increased penetration with an evenly increasing resistance.</p> <p><b>Stability and Freedom of Movement :</b> Absorbency of the mats must be balanced in order to guarantee standing, walking stability and freedom of movement.</p> <p>Indentations caused by the incidence of compressive forces must not encase the body parts, thereby hindering freedom of movements. They may not be too deep or narrow.</p> <p>If a cover is used, such cover may not plaid and create hindering folds. The mats' upper surface material must offer a balance between anti-slip and slippage. It should be neither slippery nor possess inhibiting resistance.</p> <p>By no means should mats be dislocated during performances. An anti-skid cover on the mats' underside may provide this condition.</p> <p>The border zones of the mats which are pushed together should practically have the same functional properties as the remaining surface. Impacts on the border zones should not cause different indentations than on the remaining surface. For this purpose, and to bridge joints, continuous runners are permitted.</p>

<b>II</b>
<b>MAG 11/12</b>
<b>01.01.2009</b>
<b>32</b>

## Landing mats

---

### Colour

Preference should be given to uniform colours.

The upper surface must not show optically disturbing patterns or insignia.

The FIG may designate the colour for certain events.

Norms / Functional properties  
Regarding tests carried out by FIG Tests Institutes : please see chapter IV

## Landing mats

cotes minimales en cm, minimum dimensions in cm, minimale Maße in cm

MAG 2  
cheval d'arçons  
pommel horse  
Pauschenpferd

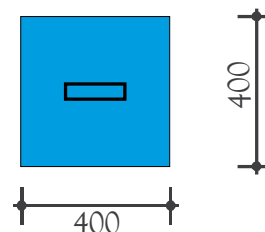

MAG 3  
anneaux  
rings  
Ringe

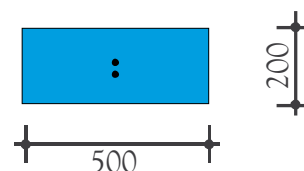

MAG 4  
saut  
vault  
Sprung

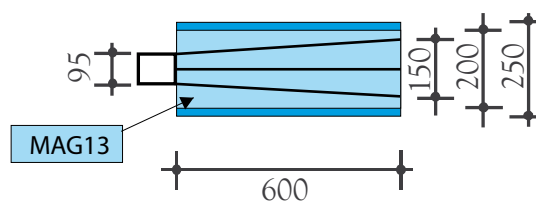

MAG 5  
barres parallèles  
parallel bars  
Barren

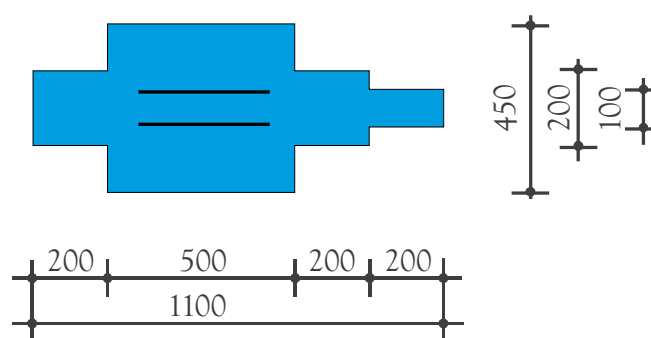

MAG 6  
barre fixe  
horizontal bar  
Reck

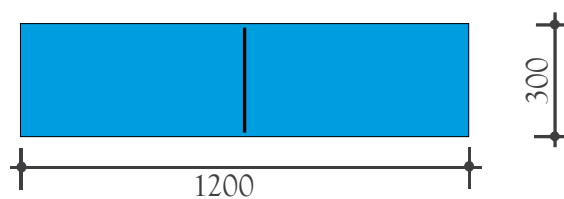

<b>II</b>
<b>MAG 13</b>
<b>01.01.2009</b>
<b>34</b>

## Supplementary mats

Use • Men's Artistic Gymnastics

### Construction / Description of material, measurements

Use	The use of a supplementary mat is compulsory for the athletes on the vault and on Horizontal bar.
Form	Their upper surface must be horizontal, even and without gaps. The supplementary mats have to be laid on the landing mats (MAG11). At the vault the supplementary mat shall be attached (i.e. using Velcro).
Measurements	<p>Height of the supplementary mats: 10 cm * 1 cm</p> <p>Vault (MAG4): 600 x 200 cm * 1 cm</p> <p>Horizontal bar (MAG6, at both sides): 400 x 200 cm * 1 cm</p> <p>* Tolerance +/-</p> <p>For the marking of the landing zone see MAG4.</p>
Functional Properties	<p>The foam of the supplementary mats shall have a density of <math>25 \text{ kg/m}^3</math> (+/- <math>2 \text{ kg/m}^3</math>). The tensile strength of the foam shall be <math>\geq 115 \text{ kPa}</math>, the compression stress value 40% shall be <math>4,0</math> (+/- <math>0.5</math>) kPa</p> <p>By no means should mats be dislocated during performances. At the vault the supplementary mat shall be attached to the landing mat</p>
Colour	<p>Preference should be given to uniform colours.</p> <p>The upper surface must not show optically disturbing patterns or insignia.</p> <p>The FIG may designate the colour for certain events.</p>

<b>II</b>
<b>MAG 14</b>
<b>01.01.2009</b>
<b>35</b>

## Vaulting board

- Use
- Men's Artistic Gymnastics
    - Vault (MAG4) – “hard” and “soft”
    - Parallel bars (MAG5) – “hard”

### Construction / Description of material, measurements

#### Form

The profile of the vaulting board must adhere exactly to the respective blue print.

Its upper surface rises in an arched form, approaching the horizontal between 75 cm and 95 cm, measured from the frontal angle. The height reached at this point, may not be exceeded. After this point, the upper surface may continue horizontally or slope downward.

The rise of the arch is 3.5 cm +/- 0,5 cm.

For competitions a “soft” and a “hard” vaulting board shall be available. The “hard” board shall be marked with a dot on the surface.

#### Measurements

- Length	120 cm	* 1 cm
- Width	60 cm	* 1 cm
- Height	20 cm	* 1 cm
- Height (run-up side)	max 3 cm	
- Cushion Cover	2 cm	* 0,5 cm
- Total height with cushion cover	22 cm	* 1,5 cm
- Free space between floor and the lower edge of the vaulting board at the run-up side	max. 1 cm	

\*Tolerance +/-

The stipulated length and height refers to the vertical projection of the upper plate, i.e. the take-off plate.

The base may be larger, but cannot extend more than 2 cm beyond the projection of the board.

Labelling of the “hard” vaulting board on the surface by a dot with clear contrast on the longitudinal midline:

Distance to the side of run up	5 cm
Diameter	8 cm

#### Functional Properties

The functional properties of the vaulting board (hardness, damping, elasticity) shall not be adjustable (i.e. springs must be fixed so that they cannot be easily removed by hand).

The elasticity of the vaulting board must be most effective in the area between 75 cm and 95 cm, measured horizontally from the frontal angle.

The vaulting-board must dampen the counter pressure, i.e. reduce motion energy.

Elasticity and absorbency must be evenly distributed, so that the effect of the vaulting board differs only slightly, regardless whether the force of the impact is at the middle axis, or away from it.

The upper surface of the vaulting board must offer slip resistance.

<b>II</b>
<b>MAG 14</b>
<b>01.01.2009</b>
<b>36</b>

## Vaulting board

### Colour

The vaulting board must not produce disturbing sounds during its use.

The board must not dislodge during use.

The vaulting board and its base may not have any sharp corners, edges and no protruding parts. Mainly the upper and under edge of the upper part of the Vaulting board towards the apparatus side (Vaulting Table, Balance Beam of Uneven Parallel Bars) shall be cushioned and rounded.

The choice of colour is left to the discretion of the manufacturer.

With exception of the dot for "hard" vaulting boards optically disturbing patterns, stripes or insignia on the upper surface are not permitted.

The FIG may designate the colour for certain events.

Norms / Functional properties  
Regarding tests carried out by FIG Tests Institutes : please see chapter IV

# Vaulting board

variante d'abaissement  
lowering variant  
Absenkungsvariante

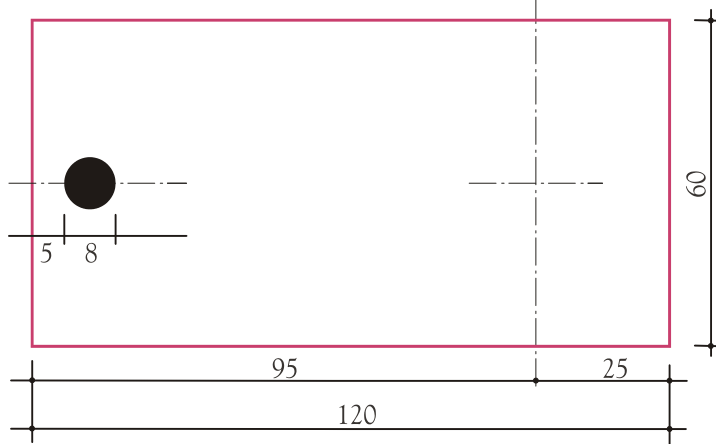
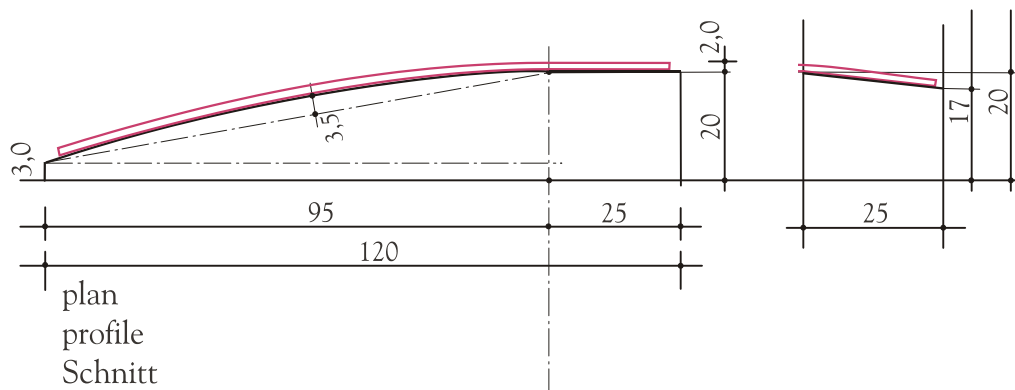

Marcage pour tremplin dur  
mark for the hard board  
Markierung für hartes Brett

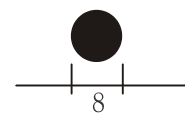

cotes obligatoires;  
construction selon le gré;  
dessin en exemple

dimensions: mandatory;  
design: at your discretion;  
drawing: typical example

Maße bindend;  
Konstruktion freigestellt;  
Zeichnung als Beispiel

<b>II</b>
<b>MAG 15</b>
<b>01.01.2009</b>
<b>38</b>

## Vaulting Board safety collar (Round off vaults)

Use • Men's Artistic Gymnastics

### Construction / Description of material, measurements

Use	The usage of the safety collar around the vaulting board is compulsory for round-off entries at the vault. It is not allowed to place the safety collar on the foot of the vaulting table or underneath the vaulting table.
Form	<p>The safety collar is "u-shaped" and surrounds the vaulting board at the sides and the front toward the vaulting table. At the sides of the vaulting board its upper surface rises in an arched form in the same level as the vaulting board. At the front side of the vaulting board the surface of the safety collar is horizontal and even.</p> <p>The whole surface of the safety collar and the corresponding surface of the vaulting board need to be of the same height level..</p>
Measurements	<p>Overall length: 120 cm (<math>\pm 1</math> cm)</p> <p>Minimal width at the side of the vaulting board: 20 cm</p> <p>Length at the front part of the vaulting board: 20 cm (<math>\pm 0,5</math> cm)</p> <p>Maximal Difference between the height of the safety collars' and the boards' surface (respecting the arched form): <math>\pm 1</math> cm</p> <p>Maximal gap between the safety collar and the vaulting board on all three sides: 0,5 cm</p>
Functional Properties	The safety collar has to provide a safe area around the vaulting board in case of an athlete misses the board for a take-off towards the vaulting table, therefore the safety collar must provide sufficient stability and cushioning at the whole upper surface. The bottom side shall have an "anti slip" surface (i.e. Velcro) to prevent the safety collar from slipping away.
Colour	The upper surface must not show optically disturbing patterns or insignia. The colour must be uniform and in contrast to the vaulting board. The FIG may designate the colour for certain events.

<b>II</b>
<b>MAG 16</b>
<b>1.01.2009</b>
<b>39</b>

## Mat for Hands (Vault)

Use • Men's Artistic Gymnastics

### Construction / Description of material, measurements

Use	A mat for hands can be used by the athletes for round-off entries on the vault
Form	The upper surface must be horizontal and even. The mat for hands can be laid on the run-up area to cushion the hand contact during round-off entries onto the vaulting board.
Measurements	<p>Length in direction of the run-up: 120 cm * +10 cm</p> <p>Width: 100 cm * ±1 cm</p> <p>Height of the mat for hands: 3 cm *±0,5 cm</p> <p>* Tolerance</p> <p style="background-color: yellow;"><i>Specifications with respect to the density for the foam of the mat are actually in progress and will be published with the next edition:</i></p> <p>The foam of the mat for hands shall have a density of <math>xx \text{ kg / m}^3</math> (+/- 2 <math>\text{kg / m}^3</math>). The ultimate tensile strength of the foam shall be <math>\geq xx \text{ kPa}</math>, the compression stress value 40% shall be <math>xx</math> (+/- <math>xx</math>) kPa</p>
Functional Properties	<p>The cover material must be non-slippery but not rough. It may not cause a burning sensation. If a cover is used, such cover may not be bulged and create hindering folds.</p> <p>The bottom side shall have an "anti slip" surface (i.e. Velcro) to prevent the mat for hands from slipping away.</p>
Colour	<p>The upper surface must not show optically disturbing patterns or insignia. The colour must be uniform and in contrast to the run-up area. The FIG may designate the colour for certain events.</p>

<b>II</b>
<b>WAG</b>
<b>01.01.2009</b>
<b>40</b>



## 2.2 WAG Women's artistic gymnastics

<b>II</b>
<b>WAG 1</b>
01.01.2011
<b>41</b>

## Vaulting Table

Use • Women's Artistic Gymnastics

### Construction / Description of material, measurements

Form	<p>The apparatus consists of a slightly inclined table body which is mounted onto a "monostand" bottom frame. The table body consists of a front surface (A) which, seen from the direction of the vault, is inclined to 8° to the vertical and merges into two arched bends (B1 and B2) and then into a linear cover surface (C) which is inclined 3° to the horizontal. The table body is divided into a bounce area (A) and a push away area (B and C) with a clear colour contrast. The different surfaces merge into each other without any gaps in between. The push away area is slightly rounded in transversal direction (D).</p> <p>All corners and edges are rounded. The bottom frame must offer the table body a stable and secure supporting surface and must guarantee the abidance by the technical safety regulations. The bottom frame with cushioning may not present any parts that protrude from under the vaulting table's body except on the landing side. As a collision protection dangerous metal parts of the support must be cushioned.</p> <p>Recommendation: All levers and locking mechanisms should be incorporated into the under construction.</p> <p>At the landing side the legs of the bottom frame must be cushioned at the same height level as the landing mat (20cm, Tolerance +10cm).</p> <p>The vaulting table including the cushioning of the bottom frame must represent a "monostand" - construction.</p>																																				
Measurements	<table style="width: 100%; border-collapse: collapse;"> <tr> <td style="width: 30%;">Table body:</td> <td style="width: 20%;">length:</td> <td style="width: 20%;">120 cm</td> <td style="width: 30%;">+/- 1 cm</td> </tr> <tr> <td></td> <td>width:</td> <td>95 cm</td> <td>+/- 1 cm</td> </tr> <tr> <td colspan="4">Height at the given measurement point (see drawing) )<sup>1</sup>: 125 cm +/-1 cm</td> </tr> <tr> <td colspan="4">Upper height at the bounce area (see drawing) )<sup>1</sup>: 112 cm +/- 1 cm</td> </tr> <tr> <td colspan="4"> <p>Remark: For competitions the vaulting table must be positioned on a rigid board which has the same height as the run up area (see below).)<sup>1</sup>:            In competitions the apparatus height must correspond to the top level of the run up area.</p> <p>Maximal orthogonal deviations from the given profile lines in longitudinal and transversal directions: &lt; 1 cm</p> <p>Protrusion of the leg construction below the table body on the landing side (only allowed with appropriate cut-outs in the landing mat):</p> <table style="width: 100%; border-collapse: collapse;"> <tr> <td style="width: 60%;"></td> <td style="width: 20%;">15 cm</td> <td style="width: 20%;">maximal</td> </tr> </table> <p>Height of the leg frame</p> <table style="width: 100%; border-collapse: collapse;"> <tr> <td style="width: 60%;"></td> <td style="width: 20%;">8 cm</td> <td style="width: 20%;">maximal</td> </tr> </table> <p>Circumference of the (cushioned) bottom frame including all levers and fixation devices between the height of 50 cm up to 85 cm</p> <table style="width: 100%; border-collapse: collapse;"> <tr> <td style="width: 60%;"></td> <td style="width: 20%;">182,8cm</td> <td style="width: 20%;">maximal</td> </tr> </table> <p>Distance between the (cushioned) leg construction including all levers and fixation devices and the projection of the table body on all four sides between the height of 50 cm up to 85 cm</p> <table style="width: 100%; border-collapse: collapse;"> <tr> <td style="width: 60%;"></td> <td style="width: 20%;">25 cm</td> <td style="width: 20%;">minimal</td> </tr> </table> </td> </tr> <tr> <td colspan="4">The adjusted height of the vaulting table must be clearly signed at the side.</td> </tr> </table>	Table body:	length:	120 cm	+/- 1 cm		width:	95 cm	+/- 1 cm	Height at the given measurement point (see drawing) ) <sup>1</sup> : 125 cm +/-1 cm				Upper height at the bounce area (see drawing) ) <sup>1</sup> : 112 cm +/- 1 cm				<p>Remark: For competitions the vaulting table must be positioned on a rigid board which has the same height as the run up area (see below).)<sup>1</sup>:            In competitions the apparatus height must correspond to the top level of the run up area.</p> <p>Maximal orthogonal deviations from the given profile lines in longitudinal and transversal directions: &lt; 1 cm</p> <p>Protrusion of the leg construction below the table body on the landing side (only allowed with appropriate cut-outs in the landing mat):</p> <table style="width: 100%; border-collapse: collapse;"> <tr> <td style="width: 60%;"></td> <td style="width: 20%;">15 cm</td> <td style="width: 20%;">maximal</td> </tr> </table> <p>Height of the leg frame</p> <table style="width: 100%; border-collapse: collapse;"> <tr> <td style="width: 60%;"></td> <td style="width: 20%;">8 cm</td> <td style="width: 20%;">maximal</td> </tr> </table> <p>Circumference of the (cushioned) bottom frame including all levers and fixation devices between the height of 50 cm up to 85 cm</p> <table style="width: 100%; border-collapse: collapse;"> <tr> <td style="width: 60%;"></td> <td style="width: 20%;">182,8cm</td> <td style="width: 20%;">maximal</td> </tr> </table> <p>Distance between the (cushioned) leg construction including all levers and fixation devices and the projection of the table body on all four sides between the height of 50 cm up to 85 cm</p> <table style="width: 100%; border-collapse: collapse;"> <tr> <td style="width: 60%;"></td> <td style="width: 20%;">25 cm</td> <td style="width: 20%;">minimal</td> </tr> </table>					15 cm	maximal		8 cm	maximal		182,8cm	maximal		25 cm	minimal	The adjusted height of the vaulting table must be clearly signed at the side.			
Table body:	length:	120 cm	+/- 1 cm																																		
	width:	95 cm	+/- 1 cm																																		
Height at the given measurement point (see drawing) ) <sup>1</sup> : 125 cm +/-1 cm																																					
Upper height at the bounce area (see drawing) ) <sup>1</sup> : 112 cm +/- 1 cm																																					
<p>Remark: For competitions the vaulting table must be positioned on a rigid board which has the same height as the run up area (see below).)<sup>1</sup>:            In competitions the apparatus height must correspond to the top level of the run up area.</p> <p>Maximal orthogonal deviations from the given profile lines in longitudinal and transversal directions: &lt; 1 cm</p> <p>Protrusion of the leg construction below the table body on the landing side (only allowed with appropriate cut-outs in the landing mat):</p> <table style="width: 100%; border-collapse: collapse;"> <tr> <td style="width: 60%;"></td> <td style="width: 20%;">15 cm</td> <td style="width: 20%;">maximal</td> </tr> </table> <p>Height of the leg frame</p> <table style="width: 100%; border-collapse: collapse;"> <tr> <td style="width: 60%;"></td> <td style="width: 20%;">8 cm</td> <td style="width: 20%;">maximal</td> </tr> </table> <p>Circumference of the (cushioned) bottom frame including all levers and fixation devices between the height of 50 cm up to 85 cm</p> <table style="width: 100%; border-collapse: collapse;"> <tr> <td style="width: 60%;"></td> <td style="width: 20%;">182,8cm</td> <td style="width: 20%;">maximal</td> </tr> </table> <p>Distance between the (cushioned) leg construction including all levers and fixation devices and the projection of the table body on all four sides between the height of 50 cm up to 85 cm</p> <table style="width: 100%; border-collapse: collapse;"> <tr> <td style="width: 60%;"></td> <td style="width: 20%;">25 cm</td> <td style="width: 20%;">minimal</td> </tr> </table>					15 cm	maximal		8 cm	maximal		182,8cm	maximal		25 cm	minimal																						
	15 cm	maximal																																			
	8 cm	maximal																																			
	182,8cm	maximal																																			
	25 cm	minimal																																			
The adjusted height of the vaulting table must be clearly signed at the side.																																					

<b>II</b>
<b>WAG 1</b>
01.01.2011
<b>42</b>

## Vaulting Table

Functional Properties	<p>Additional Measurements see drawing. The profile lines towards A, B1, B2 and D are to be respected as indicated in the drawing. Maximum deviations &lt; 1 cm – measured at a right angle to the profile line.</p> <p>The push away area must be shock-absorbing so that shoulders and wrists are protected.</p> <p>The rebound properties must be guaranteed to be as homogeneously as possible for all the possible impact points on the table body.</p> <p>Extended time-shift for rebounding energy at the impact points caused by extreme deflections is not acceptable.</p> <p>The table body must be evenly cushioned over the entire push away area. The cover material must be non-slippery but not rough. It may not cause a burning sensation on sliding.</p> <p>The bounce area must be cushioned with a high-quality material in order to provide a good collision protection.</p> <p>Recommendation: Any protruding items covered by the cushioning of the stand should be avoided or sufficiently covered to prevent perforation through the cushioning during accidental impact.</p>										
Colour	<p>In order to avoid swaying, vibrations and shifting, the apparatus must have a device for fastening it to the floor</p>										
Run up area	<p>The colour of the surface material may be chosen according to taste. For certain events the colour may be determined by the FIG.</p> <p>The run-up area is composed of a run-up mat and a rigid board underneath the vaulting board.</p> <p>The start of the run-up (2500 cm) shall be marked.</p> <table style="width: 100%; border-collapse: collapse;"> <tr> <td style="padding: 2px;">length (measured from the vertical projection of the beginning of the vaulting table – see “reference point” in the drawing)</td> <td style="text-align: right; padding: 2px;">2500 + 10 cm</td> </tr> <tr> <td style="padding: 2px;">width (run-up mat)</td> <td style="text-align: right; padding: 2px;">100 cm +/- 1 cm</td> </tr> <tr> <td style="padding: 2px;">width (rigid board underneath)</td> <td style="text-align: right; padding: 2px;">100 cm min.</td> </tr> <tr> <td style="padding: 2px;">height (same height for run-up mat and board underneath)</td> <td style="text-align: right; padding: 2px;">max 2,5 cm</td> </tr> <tr> <td style="padding: 2px;">length of the rigid board underneath the vaulting board</td> <td style="text-align: right; padding: 2px;">320 cm +/- 1 cm</td> </tr> </table> <p>The colour of the run-up area must have a clear contrast to the colour of the vaulting board. The whole run up area (run-up mat and the rigid board underneath) shall have the same colour.</p>	length (measured from the vertical projection of the beginning of the vaulting table – see “reference point” in the drawing)	2500 + 10 cm	width (run-up mat)	100 cm +/- 1 cm	width (rigid board underneath)	100 cm min.	height (same height for run-up mat and board underneath)	max 2,5 cm	length of the rigid board underneath the vaulting board	320 cm +/- 1 cm
length (measured from the vertical projection of the beginning of the vaulting table – see “reference point” in the drawing)	2500 + 10 cm										
width (run-up mat)	100 cm +/- 1 cm										
width (rigid board underneath)	100 cm min.										
height (same height for run-up mat and board underneath)	max 2,5 cm										
length of the rigid board underneath the vaulting board	320 cm +/- 1 cm										
Authorized Landing zone	<p>Marking on the supplementary mat above the landing mat (see drawing).</p> <table style="width: 100%; border-collapse: collapse;"> <tr> <td style="padding: 2px;">Width of the landing corridor at the table site:</td> <td style="text-align: right; padding: 2px;">95 cm</td> </tr> <tr> <td style="padding: 2px;">Width of the landing corridor (end of 600 cm landing mat):</td> <td style="text-align: right; padding: 2px;">150 cm</td> </tr> </table> <p>When the authorized landing zone is marked out by stripes:</p> <table style="width: 100%; border-collapse: collapse;"> <tr> <td style="padding: 2px;">Marking strip width on the supplementary mat</td> <td style="text-align: right; padding: 2px;">5 cm +/-0.5 cm</td> </tr> </table> <p>The marking strip is part of the authorized landing zone.</p> <table style="width: 100%; border-collapse: collapse;"> <tr> <td style="padding: 2px;">Additional marking strip width in the centre of the landing corridor (see drawing):</td> <td style="text-align: right; padding: 2px;">5 cm +/-0.5 cm</td> </tr> </table> <p><i>Remarks concerning the drawings:</i></p> <ul style="list-style-type: none"> <li>- Bottom frame construction schematized.</li> <li>- All dimensions in cm</li> <li>- Tolerances for all dimensions: +/- 1cm</li> <li>- Maximal Orthogonal Deviations from the given profiles in longitudinal and transversal directions: &lt;1 cm</li> </ul> <p>Dimensions binding; Construction may be different– drawing as example.</p>	Width of the landing corridor at the table site:	95 cm	Width of the landing corridor (end of 600 cm landing mat):	150 cm	Marking strip width on the supplementary mat	5 cm +/-0.5 cm	Additional marking strip width in the centre of the landing corridor (see drawing):	5 cm +/-0.5 cm		
Width of the landing corridor at the table site:	95 cm										
Width of the landing corridor (end of 600 cm landing mat):	150 cm										
Marking strip width on the supplementary mat	5 cm +/-0.5 cm										
Additional marking strip width in the centre of the landing corridor (see drawing):	5 cm +/-0.5 cm										

Norms / Functional properties  
Regarding tests carried out by FIG Tests Institutes : please see chapter IV

II
WAG 1
01.01.2011
43

# Vaulting Table

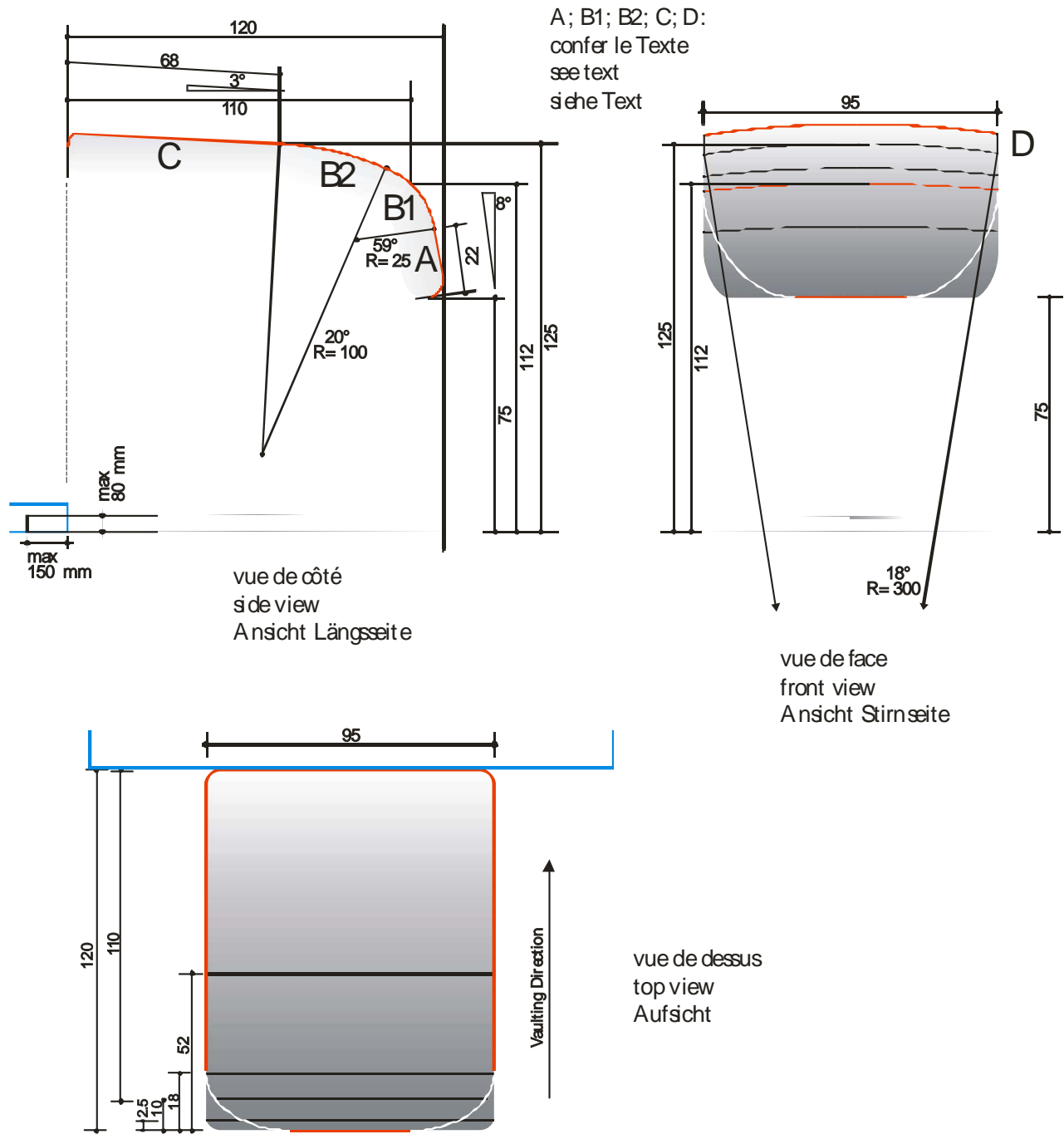

cotes obligatoires;  
construction selon le gré;  
dessin en exemple

dimensions: mandatory;  
design: at your discretion;  
drawing: typical example

Maße bindend;  
Konstruktion freigestellt;  
Zeichnung als Beispiel

<b>II</b>
<b>WAG 1</b>
01.01.2011
<b>44</b>

## Vaulting Table

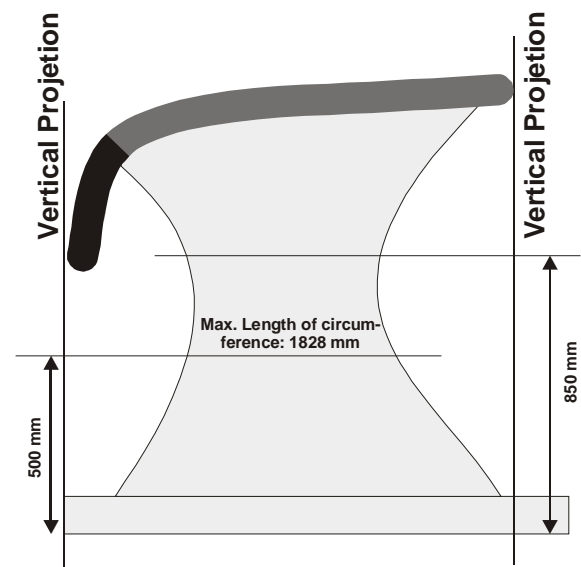
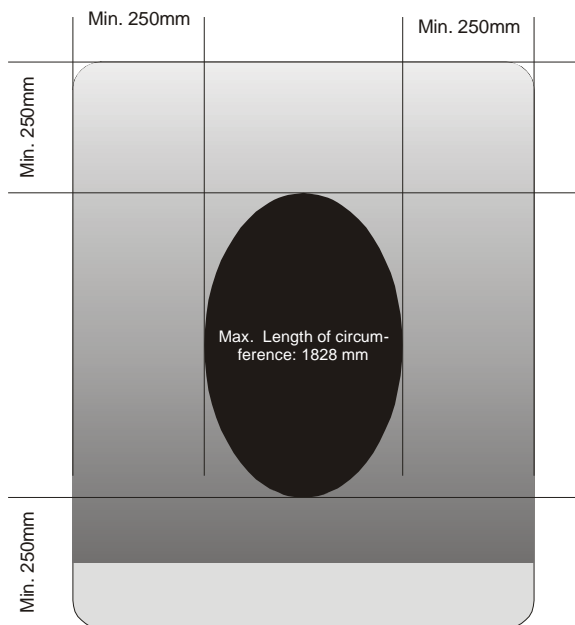

cotes obligatoires;  
 construction selon le gré;  
 dessin en exemple

dimensions: mandatory;  
 design: at your discretion;  
 drawing: typical example

Maße bindend;  
 Konstruktion freigestellt;  
 Zeichnung als Beispiel

<b>II</b>
<b>WAG 1</b>
01.01.2011
<b>45</b>

# Vaulting Table

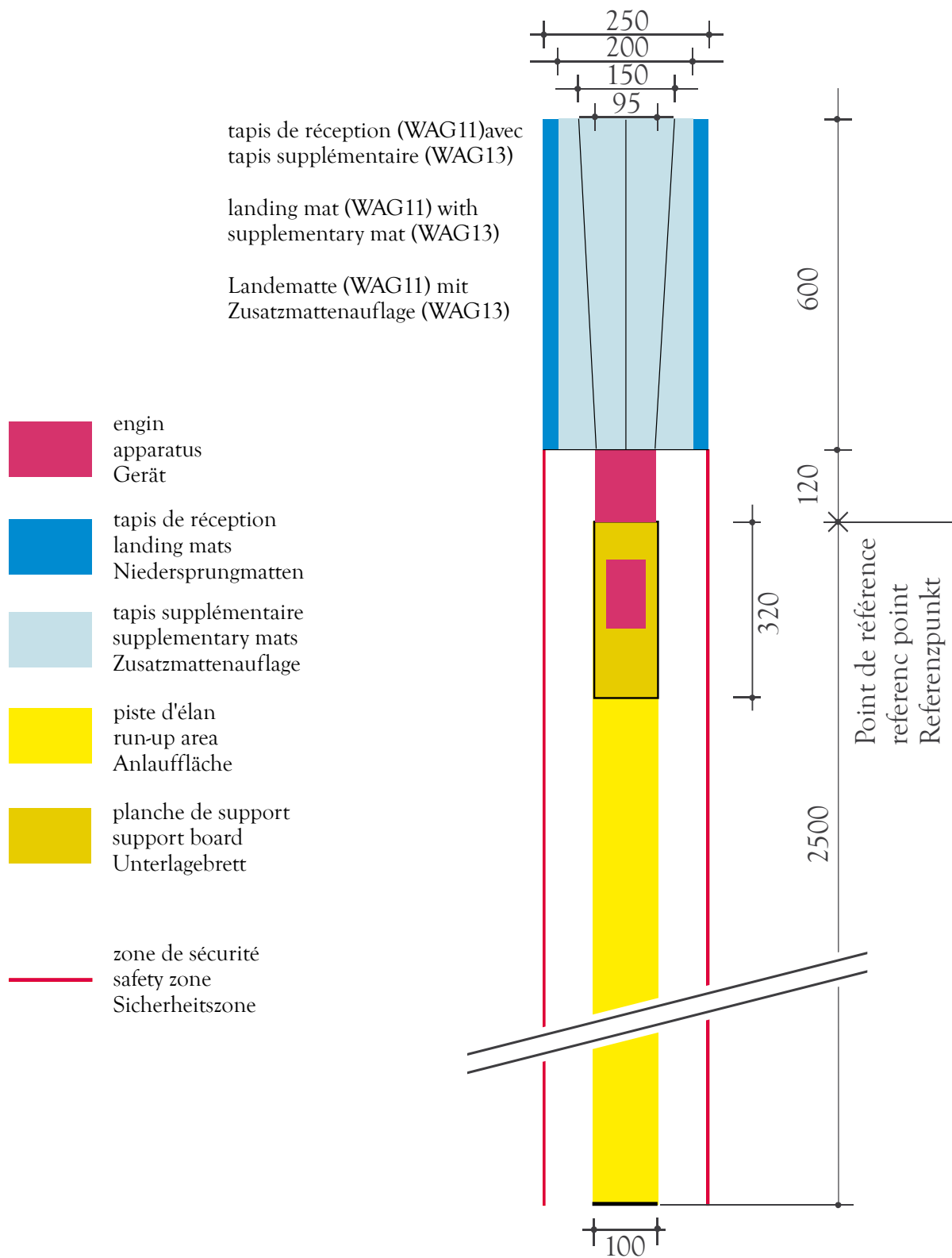

<b>II</b>
<b>WAG 2</b>
01.01.2011
<b>46</b>

## Uneven Bars

Use • Women's Artistic Gymnastics

### Construction / Description of material, measurements

Form	<p>The apparatus consists of two bars, which run parallel, but at different heights, and are carried by a support base.</p> <p>The support base has four uprights, which are held by tension cables (<math>\varnothing</math> max 1 cm) anchored to the floor.</p> <p>Each bar is carried by 2 supports.</p> <p>One low and one high support are connected to a floor device and a width adjustment device.</p>																					
Measurements	<p>Bars :</p> <table style="margin-left: 40px;"> <tr><td>Diameter</td><td style="text-align: right;">4,0 cm</td><td style="text-align: right;">* 0,1 cm</td></tr> <tr><td>Length</td><td style="text-align: right;">240 cm</td><td style="text-align: right;">* 1,0 cm</td></tr> <tr><td>Distance between the sockets</td><td style="text-align: right;">min 200 cm</td><td style="text-align: right;">* 1,0 cm</td></tr> </table> <p>Height of the <u>upper</u> edge of the bars in inner diagonal position 180 cm:</p> <table style="margin-left: 40px;"> <tr><td>upper bar (to the floor)</td><td style="text-align: right;">250 cm</td><td style="text-align: right;">* 1,0 cm</td></tr> <tr><td>lower bar (to the floor)</td><td style="text-align: right;">170 cm</td><td style="text-align: right;">* 1,0 cm</td></tr> </table> <p>Inner diagonal distance (see drawing) between the 2 bars adjustable from min 130 - 180 cm max * 1,0 cm The diagonal distance must be adjustable continuously or with increments of max 2 cm. The diagonal distance (expressed in cm) must be shown on a scale at the distance adjustment device. Height changes at competitions to additional 10 cm may only be allowed with specific, solid support plates. Height increases of 10 cm shall be allowed in competitions for gymnasts who touch the mat with their feet during the exercise. This must be announced to the organizers at the time of the nominative entry and verified by the President or a member of the Superior Jury during the training. Organizers/Equipment suppliers must provide minimum one pair of 10 cm support plates in each "hall" (competition hall, warm-up hall, training hall).</p> <p>Distance of floor anchors :</p> <table style="margin-left: 40px;"> <tr><td>lengthwise</td><td style="text-align: right;">550 cm</td><td style="text-align: right;">* 5 cm</td></tr> <tr><td>crosswise</td><td style="text-align: right;">400 cm</td><td style="text-align: right;">* 5 cm</td></tr> </table>	Diameter	4,0 cm	* 0,1 cm	Length	240 cm	* 1,0 cm	Distance between the sockets	min 200 cm	* 1,0 cm	upper bar (to the floor)	250 cm	* 1,0 cm	lower bar (to the floor)	170 cm	* 1,0 cm	lengthwise	550 cm	* 5 cm	crosswise	400 cm	* 5 cm
Diameter	4,0 cm	* 0,1 cm																				
Length	240 cm	* 1,0 cm																				
Distance between the sockets	min 200 cm	* 1,0 cm																				
upper bar (to the floor)	250 cm	* 1,0 cm																				
lower bar (to the floor)	170 cm	* 1,0 cm																				
lengthwise	550 cm	* 5 cm																				
crosswise	400 cm	* 5 cm																				
Functional Properties	<p>Both bars must have the same, uniform elasticity. To assure this, their supports must be articulated.</p> <p>The bar surface must provide a good glide and turn capability but may not be slippery.</p> <p>To ensure grip stability, the bars' surface must absorb moisture.</p> <p>The bars must be secured (reinforced) against breaking through.</p> <p>A safeguard system must prevent an unintended release of the movable components of the apparatus.</p> <p>When the apparatus is used for performances, no hindering sways or</p>																					

<b>II</b>
<b>WAG 2</b>
01.01.2011
<b>47</b>

## Uneven Bars

Colour	vibrations and counter swings should occur. The bars retain the natural colour of wood. They are neither lacquered, nor polished.
Norms / Functional properties Regarding tests carried out by FIG Tests Institutes : please see chapter IV	

# Uneven Bars

point du mesure pour différents systèmes  
de fixation de la barre  
measurement point with variantes of supports  
Meßstelle bei Varianten von Holmauflagen

vue de face  
front view  
Frontansicht

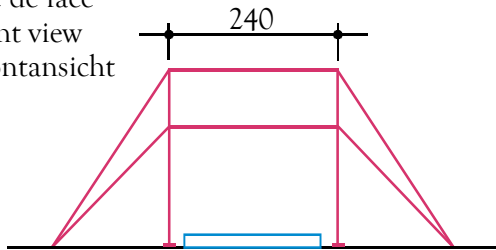

vue de côté  
side view  
Seitenansicht

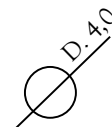
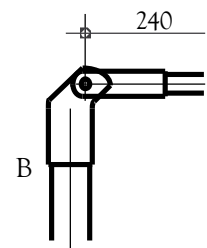
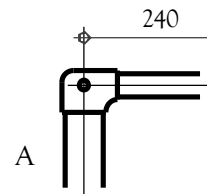
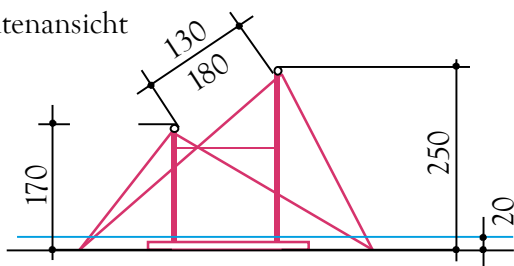

porte-main  
bar  
Barrenholm

vue de dessus  
top view  
Aufsicht

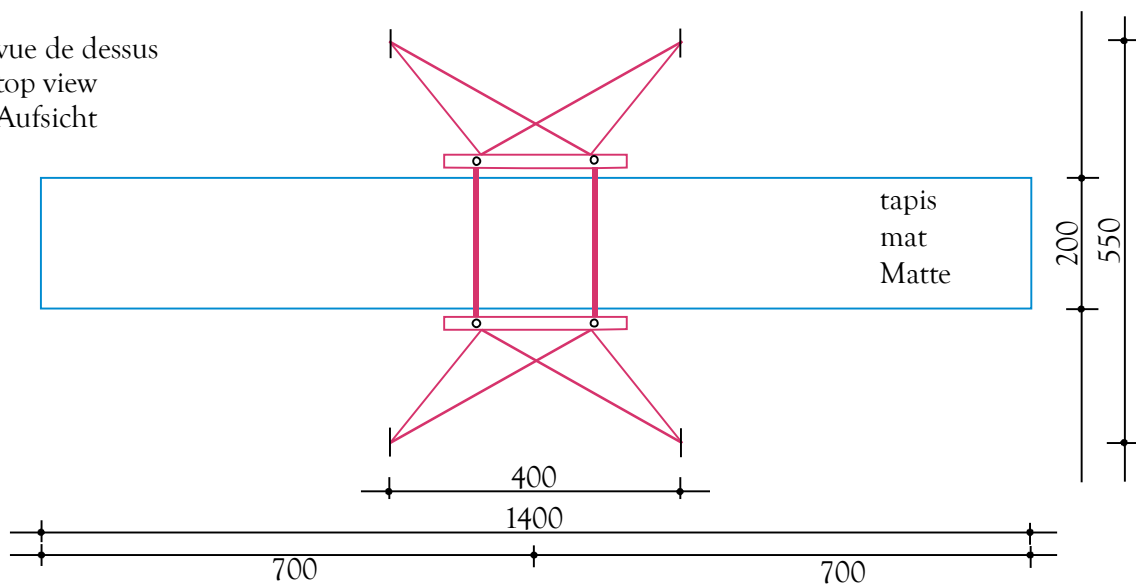

surface d'appui 550 x 1400  
floor area for apparatus 550 x 1400  
Gerätstellfläche 550 x 1400

cotes obligatoires;  
construction selon le gré;  
dessin en exemple

dimensions: mandatory;  
design: at your discretion;  
drawing: typical example

Maße bindend;  
Konstruktion freigestellt;  
Zeichnung als Beispiel

<b>II</b>
<b>WAG 3</b>
01.01.2011
<b>49</b>

## Balance Beam

Use • Women's Artistic Gymnastics

### Construction / Description of material, measurements

#### Form

The apparatus consists of a beam, which is held by a base consisting of 2 supports.

Lengthwise, the beam shall be straight and its upper surface and axis shall be even and horizontal.

Viewed in cross section, the sides of the beam are arched.

The base design is not prescribed.

However, its legs may not protrude beyond the projection of the beam in its longitudinal direction. The supports of the beam must be cushioned. The cushioned parts shall not protrude the vertical projection of the beam.

The front parts of the beam must be cushioned by rounded, damping padding. The padding must reach the top edge of the beam, but the radius of the rounding must begin immediately at the end of the beam to guarantee that the padding does not prolong the total length of the beam (examples see drawing)

#### Measurements

Beam :

Length	500 cm	* 1 cm
Cross section: - Upper surface	10 cm	* 0,5 cm
- Horizontal axis	13 cm	* 0,5 cm
- Vertical axis	16 cm	* 0,5 cm
- Bottom surface	10 cm	* 0,5 cm

Height of upper surface measured from the floor	125 cm	* 1 cm
---	--------	--------

Legs of base:

Distance	max. 500 cm
Width	max. 125 cm

Cushioning of the supports:

Thickness	min. 15 mm
Width of the supports incl. cushioning	max. 13 cm

Cushioning of the front parts of the beam:

Thickness	min. 15 mm up to max. 30 mm
-----------	-----------------------------

The Beam might have a height adjustment. It can be continuous or in 5 cm increments. However, the prescribed height of 125 cm \* 1cm shall be observed at competition site.

Continuous height adjustment is recommended for levelling purposes.

<b>II</b>
<b>WAG 3</b>
01.01.2011
<b>50</b>

## Balance Beam

### Functional Properties

The surface must have impact absorbent characteristics to protect the gymnast's joints and limbs. It should also have elasticity to support the jumps.

One of the most important properties of the beam is that it must be step safe. Elasticity must be equally distributed and must not disturb a sure step.

The upper surface material of the beam must permit effortless gliding and turning, but not be slippery.

The front parts of the beam must be padded.

The cover material must not produce skin burns.

The upper edge of the padding at the front parts of the beam shall not be harder than the surface of the beam.

All protruding parts, especially screws underneath the balance beam shall be cushioned or hidden.

During an exercise, the beam may not move, topple or sway.

### Colour

The colour of the beam must distinctly differ from the colour of the mats.

Norms / Functional properties  
Regarding tests carried out by FIG Tests Institutes : please see chapter IV

II
WAG 3
01.01.2011
51

# Balance Beam

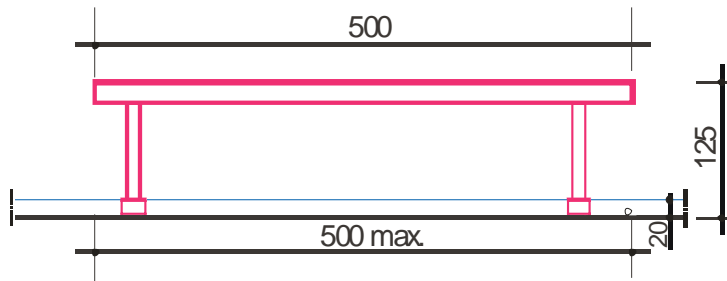

vue de côté  
side view  
Ansicht Längsseite

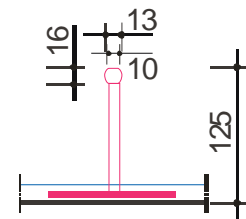

vue de face  
front view  
Ansicht Stirnseite

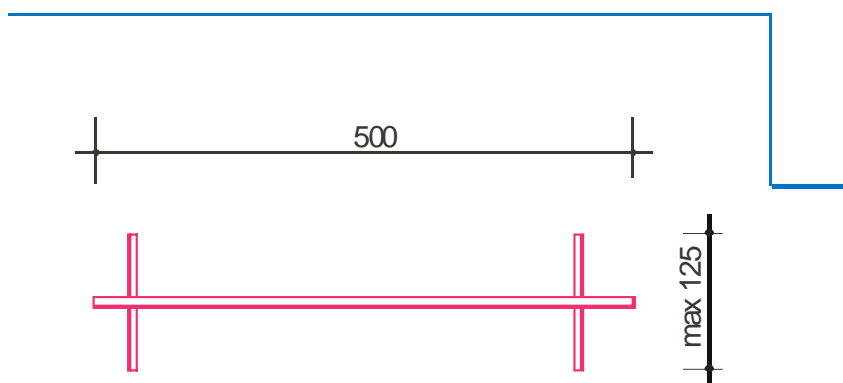

vue de dessus  
top view  
Aufsicht

coupe longitudinale  
beam end, longitudinal  
Längsschnitt Balkenkopf

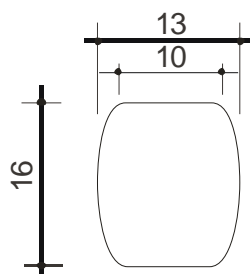

coupe transversale  
de la poutre  
beam, cross-section  
Balken-Querschnitt

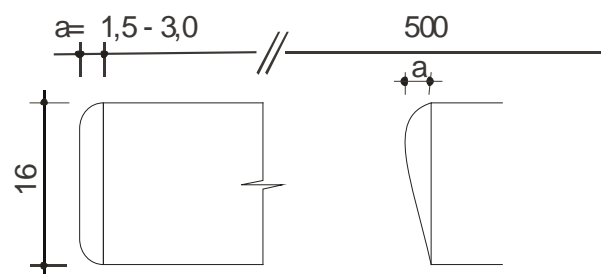

Variante

cotes obligatoires;  
construction selon le gré;  
dessin en exemple

dimensions mandatory;  
design: at your discretion;  
drawing: typical example

Maße bindend;  
Konstruktion freigestellt;  
Zeichnung als Beispiel



<b>II</b>
<b>WAG 4</b>
<b>01.01.2009</b>
<b>53</b>

Floor

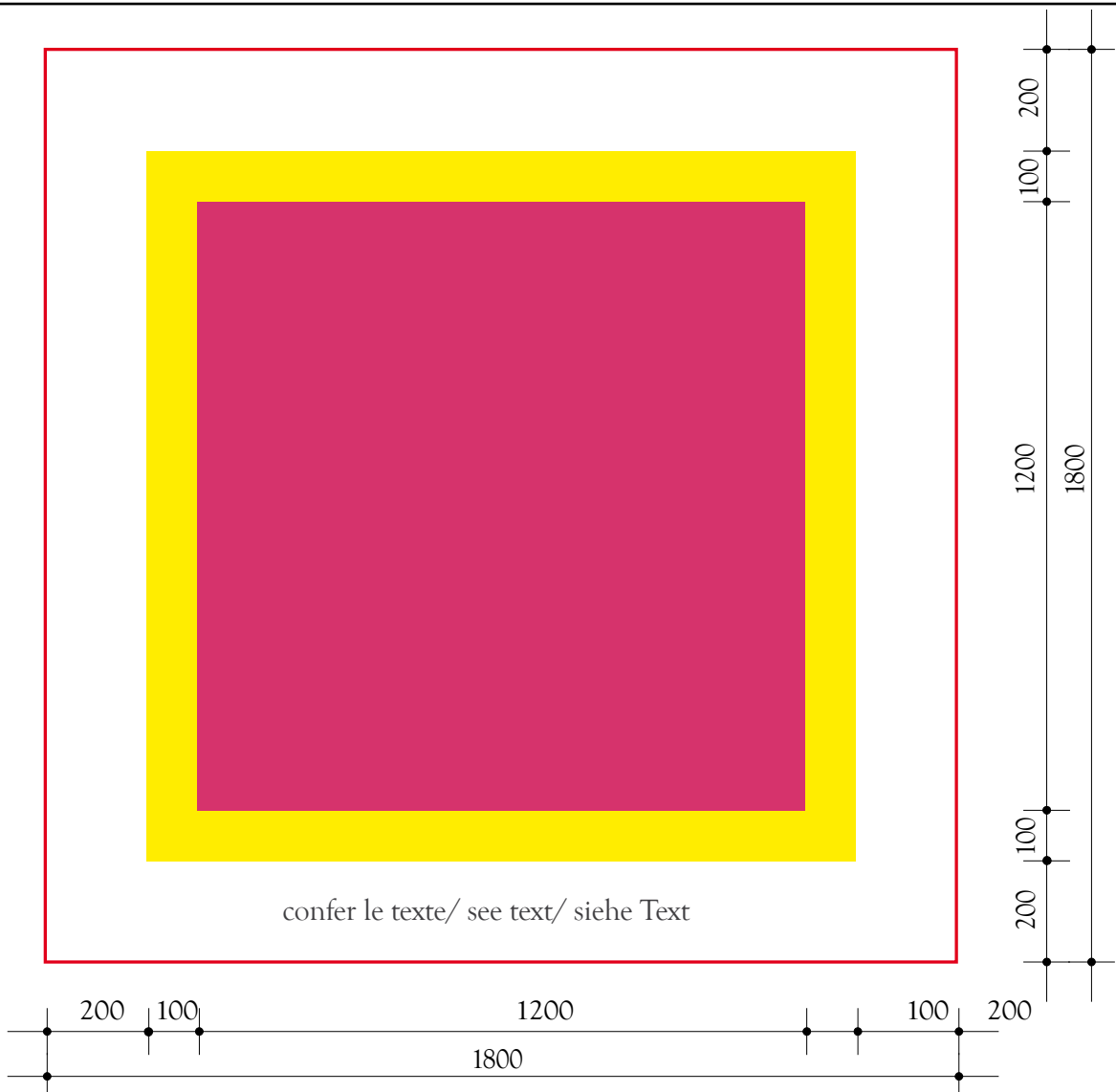

- surface de compétition, arena, Wettkampffläche
- cadre, edge, Umrandung
- zone de sécurité, safety zone, Sicherheitszone

variantes, profile - variants, Schnitt - Varianten A, B, C

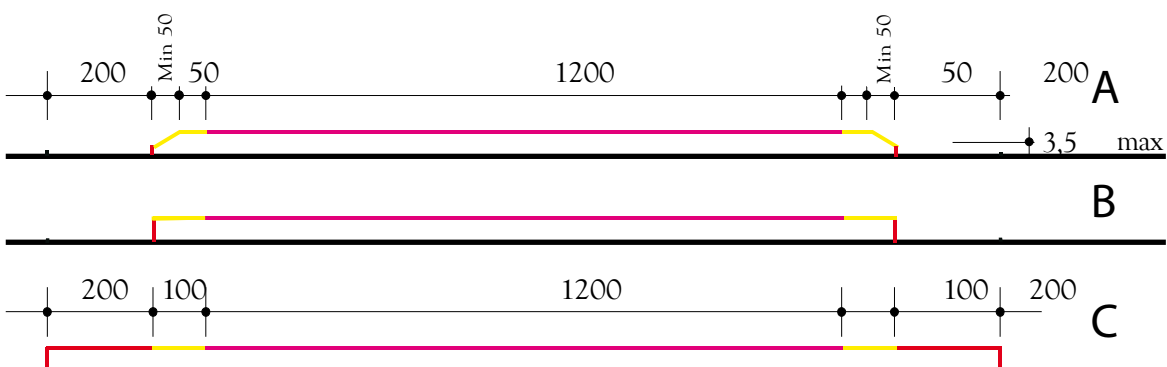

<b>II</b>
<b>WAG 11</b>
<b>27.03.2008</b>
<b>54</b>

## Landing Mats

Use • Women's Artistic Gymnastics

### Construction / Description of material, measurements

Form	<p>Their upper surface must be horizontal, even and without gaps.</p> <p>Specially designed mats must be used to cover the basis of the apparatus evenly.</p>
Measurements	<p>Height of landing mats (WAG1, WAG2, WAG3):                      20 cm    +/- 1 cm</p> <p>Width and length see drawing</p>
Functional Properties	<p>Absorbency: The mats must absorb motion energy, in order to reduce the reaction transmitted to the body of the landing gymnast, to a tolerable proportion.</p> <p>They must respond to increased penetration with an evenly increasing resistance.</p> <p>Stability and Freedom of Movement : Absorbency of the mats must be balanced in order to guarantee standing, walking stability and freedom of movement, there must be an equal balance between elasticity and absorbency properties.</p> <p>Indentations caused by the incidence of compressive forces must not encase the body parts, thereby hindering freedom of movements mainly of rolling a part of the body.</p> <p>If a cover is used, such cover may not cause hindering folds. The mats' upper surface material must offer a balance between anti-slip and slippage. It must be neither slippery nor possess inhibitory resistance.</p> <p>By no means should mats be dislocated during performances. An anti-skid cover on the mats' underside may provide this condition.</p> <p>The border zones of the mats which are pushed together should practically have the same functional properties as the remaining surface. Impacts on the border zones should not cause different indentations than on the remaining surface. For this purpose, and to bridge joints, continuous runners are permitted.</p>
Colour	<p>Preference should be given to uniform colours.</p> <p>The upper surface must not show optically disturbing patterns or insignia.</p> <p>The FIG may designate the colour of certain events.</p>

Norms / Functional properties  
Regarding tests carried out by FIG Tests Institutes : please see chapter IV

<b>II</b>
<b>WAG 11</b>
<b>27.03.2008</b>
<b>55</b>

## Landing Mats

cotes minimales en cm, minimum dimensions in cm, minimale Maße in cm

WAG 1  
saut  
vault  
Sprung

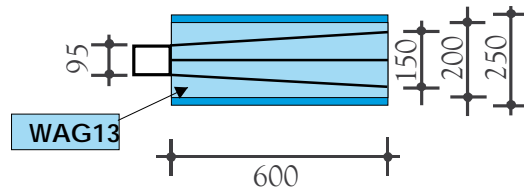

WAG 3  
barres asymétriques  
uneven bars  
Stufenbarren

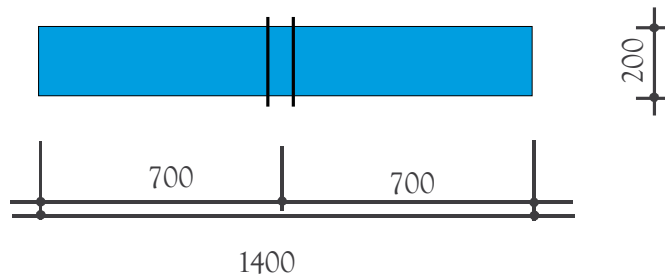

WAG 2  
poutre  
beam  
Balken

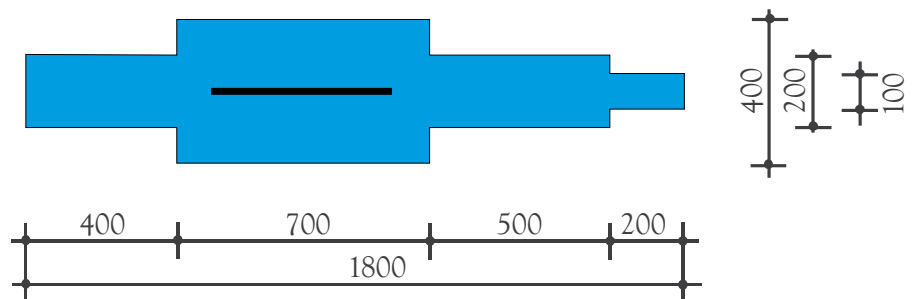

<b>II</b>
<b>WAG 13</b>
<b>01.01.2009</b>
<b>56</b>

## Supplementary Mats

Use • Women's Artistic Gymnastics

### Construction / Description of material, measurements

Use	The usage is compulsory for the athletes at Uneven Bars, Balance Beam and at the vault.
Form	Their upper surface must be horizontal, even and without gaps. The supplementary mats have to be laid on the landing mats (WAG11). At the vault the supplementary mat shall be attached (i.e. using Velcro).
Measurements	<p>Height of the supplementary mats: 10 cm * 1 cm</p> <p>Vault (WAG1): 600 x 200 cm * 1 cm</p> <p>Uneven bars, balance beam (WAG2, WAG 3): 400 x 200 cm * 1 cm</p> <p>* Tolerance +/-</p> <p>For the marking of the landing zone see WAG1.</p>
Functional Properties	<p>The foam of the supplementary mats shall have a density of <math>25 \text{ kg / m}^3</math> (+/- <math>2 \text{ kg / m}^3</math>). The ultimate tensile strength of the foam shall be <math>\geq 115 \text{ kPa}</math>, the compression stress value 40% shall be <math>4,0</math> (+/- <math>0.5</math>) kPa</p> <p>By no means should mats be dislocated during performances. At the vault the supplementary mat shall be attached to the landing mat</p>
Colour	<p>Preference should be given to uniform colours.</p> <p>The upper surface must not show optically disturbing patterns or insignia.</p> <p>The FIG may designate the colour for certain events.</p>

<b>II</b>
<b>WAG 14</b>
<b>01.01.2009</b>
<b>57</b>

## Vaulting Board

- Use
- Women's Artistic Gymnastics
    - Vault (WAG1) – “hard” and “soft”
    - Uneven bars (WAG2) – “soft”
    - Balance beam (WAG3) – “soft”

### Construction / Description of material, measurements

#### Form

The profile of the vaulting board must adhere exactly to the respective blue print.

Its upper surface rises in an arched form, approaching the horizontal between 75 cm and 95 cm, measured from the frontal angle. The height reached at this point, may not be exceeded. After this point, the upper surface may continue horizontally or slope downward.

The rise of the arch is 3.5 cm +/- 0,5 cm.

For competitions a “soft” and a “hard” vaulting board shall be available. The “hard” board shall be marked with a dot on the surface.

#### Measurements

- Length	120 cm	* 1 cm
- Width	60 cm	* 1 cm
- Height	20 cm	* 1 cm
- Height (run-up side)	max 3 cm	
- Cushion Cover	2 cm	* 0,5 cm
- Total height with cushion cover	22 cm	* 1,5 cm
- Free space between floor and the lower edge of the vaulting board at the run-up side	max. 1 cm	

\*Tolerance +/-

The stipulated length and height refers to the vertical projection of the upper plate, i.e. the take-off plate.

The base may be larger, but cannot extend more than 2 cm beyond the projection of the board.

Labelling of the “hard” vaulting board on the surface by a dot with clear contrast on the longitudinal midline:

Distance to the side of run up	5 cm
Diameter	8 cm

#### Functional Properties

The functional properties of the vaulting board (hardness, damping, elasticity) shall not be adjustable (i.e. springs must be fixed so that they cannot be easily removed by hand).

The elasticity of the vaulting board must be most effective in the area between 75 cm and 95 cm, measured horizontally from the frontal angle.

The vaulting-board must dampen the counter pressure, i.e. reduce motion energy.

Elasticity and absorbency must be evenly distributed, so that the effect of the vaulting board differs only slightly, regardless whether the force of the impact is at the middle axis, or away from it.

<b>II</b>
<b>WAG 14</b>
<b>01.01.2009</b>
<b>58</b>

## Vaulting Board

### Colour

The upper surface of the vaulting board must offer slip resistance.

The vaulting board must not produce disturbing sounds during its use.

The vaulting board must not dislodge during use.

The vaulting board and its base may not have any sharp corners, edges and no protruding parts. Mainly the upper and under edge of the upper part of the Vaulting board towards the apparatus side (Vaulting Table, Balance Beam or Uneven Parallel Bars) shall be cushioned and rounded.

The choice of colour is left to the discretion of the manufacturer.

With exception of the dot for "hard" vaulting boards optically disturbing patterns, stripes or insignia on the upper surface are not permitted.

The FIG may designate the colour for certain events.

Norms / Functional properties  
Regarding tests carried out by FIG Tests Institutes : please see chapter IV

Vaulting Board

variante d'abaissement  
lowering variant  
Absenkungsvariante

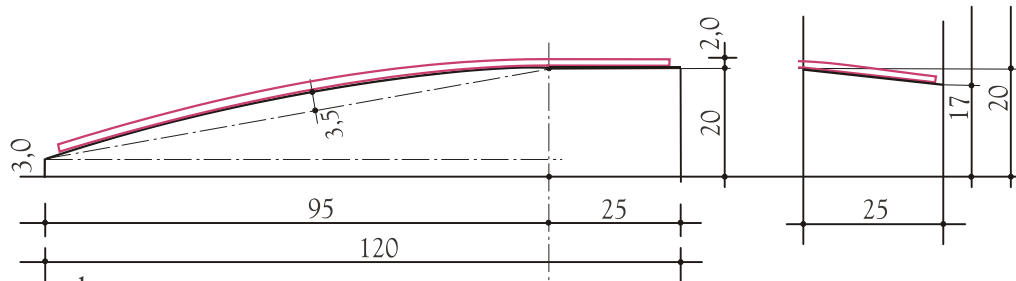

plan  
profile  
Schnitt

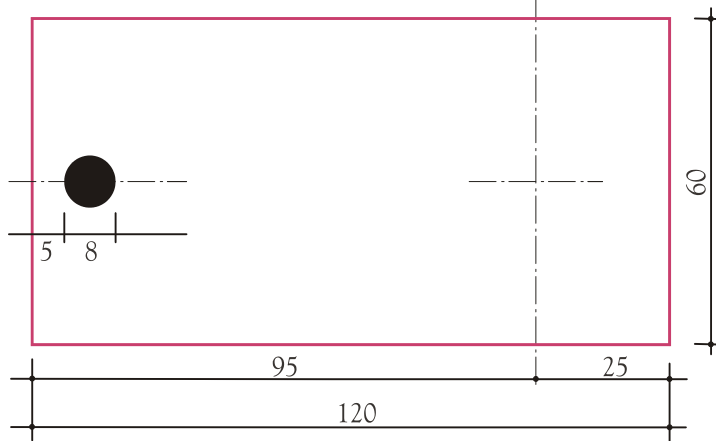

vue de dessus  
top view  
Aufsicht

Marcage pour tremplin dur  
mark for the hard board  
Markierung für hartes Brett

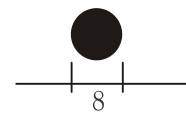

cotes obligatoires;  
construction selon le gré;  
dessin en exemple

dimensions: mandatory;  
design: at your discretion;  
drawing: typical example

Maße bindend;  
Konstruktion freigestellt;  
Zeichnung als Beispiel

<b>II</b>
<b>WAG 15</b>
<b>01.01.2009</b>
<b>60</b>

## Vaulting Board safety collar (Round off vaults)

Use • Women's Artistic Gymnastics

### Construction / Description of material, measurements

Use	The usage of the safety collar around the vaulting board is compulsory for round-off entries at the vault. It is not allowed to place the safety collar on the foot of the vaulting table or underneath the vaulting table.
Form	<p>The safety collar is "u-shaped" and surrounds the vaulting board at the sides and the front toward the vaulting table. At the sides of the vaulting board its upper surface rises in an arched form in the same level as the vaulting board. At the front side of the vaulting board the surface of the safety collar is horizontal and even.</p> <p>The whole surface of the safety collar and the corresponding surface of the vaulting board need to be of the same height level..</p>
Measurements	<p>Overall length: 120 cm (<math>\pm 1</math> cm)</p> <p>Minimal width at the side of the vaulting board: 20 cm</p> <p>Length at the front part of the vaulting board: 20 cm (<math>\pm 0,5</math> cm)</p> <p>Maximal Difference between the height of the safety collars' and the boards' surface (respecting the arched form): <math>\pm 1</math> cm</p> <p>Maximal gap between the safety collar and the vaulting board on all three sides: 0,5 cm</p>
Functional Properties	The safety collar has to provide a safe area around the vaulting board in case of an athlete misses the board for a take off towards the vaulting table, therefore the safety collar must provide sufficient stability and cushioning at the whole upper surface. The bottom side shall have an "anti slip" surface (i.e. velcro) to prevent the safety collar from slipping away.
Colour	<p>The upper surface must not show optically disturbing patterns or insignia. The colour must be uniform and in contrast to the vaulting board.</p> <p>The FIG may designate the colour for certain events.</p>

II
WAG 16
01.01.2009
61

## Mat for Hands (Vault)

Use • Women's Artistic Gymnastics

### Construction / Description of material, measurements

Use	A mat for hands can be used by the athletes for round-off entries on the vault		
Form	The upper surface must be horizontal and even. The mat for hands can be laid on the run-up area to cushion the hand contact during round-off entries onto the vaulting board.		
Measurements	Length in direction of the run-up:	120 cm	* +10 cm
	Width:	100 cm	* ±1 cm
	Height of the mat for hands:	3 cm	* ±0,5 cm
	* Tolerance		
	<i>Specifications with respect to the density for the foam of the mat are actually in progress and will be published with the next edition:</i>		
Functional Properties	The foam of the mat for hands shall have a density of $xx \text{ kg / m}^3$ (+/- 2 $\text{kg / m}^3$ ). The ultimate tensile strength of the foam shall be $\geq xx \text{ kPa}$ , the compression stress value 40% shall be $xx$ (+/- $xx$ ) $\text{kPa}$		
	The cover material must be non-slippery but not rough. It may not cause a burning sensation. If a cover is used, such cover may not be bulged and create hindering folds. The bottom side shall have an "anti slip" surface (i.e. velcro) to prevent the mat for hands from slipping away.		
Colour	The upper surface must not show optically disturbing patterns or insignia. The colour must be uniform and in contrast to the run-up area. The FIG may designate the colour for certain events.		

<b>II</b>
<b>RG</b>
<b>01.01.2009</b>
<b>63</b>



## 2.3 RG Rhythmic gymnastics

<b>II</b>
<b>RG 1</b>
01.01.2011
<b>64</b>

## Performance Area

Use • Rhythmic Gymnastics

### Construction / Description of material, measurements

Form	<p>The Performance Area shall have a square format. The surface must be horizontal, even and without gaps.</p> <p>Border :</p> <p>Horizontal, even, and at the same height as the performance area.</p> <p>Safety zone:</p> <p>The safety zone shall be kept totally free as a surrounding zone around the performance area and the border. It shall be horizontal, even and without gaps.</p> <p>Direction of carpet seams:</p> <p>If the surface is composed of several parallel carpet rolls, the seams shall be perpendicular to the direction of the judges' tables.</p>																											
Measurements	<table style="width: 100%; border-collapse: collapse;"> <tr> <td style="width: 60%;">Performance area</td> <td style="width: 20%; text-align: center;">1300 x</td> <td style="width: 20%; text-align: right;">1300 cm</td> </tr> <tr> <td></td> <td></td> <td style="text-align: right;">Tolerance +/- 3 cm</td> </tr> <tr> <td>Diagonals of the performance area:</td> <td></td> <td style="text-align: right;">1838 cm +/- 5cm</td> </tr> <tr> <td>Border (25 + 25)</td> <td></td> <td style="text-align: right;">50 cm</td> </tr> <tr> <td>Safety border</td> <td></td> <td style="text-align: right;">200 cm</td> </tr> <tr> <td>Border as a variant</td> <td></td> <td></td> </tr> <tr> <td>Horizontal Area, Width</td> <td style="text-align: center;">25 cm</td> <td></td> </tr> <tr> <td>Slope max. 20 %, Width</td> <td style="text-align: center;">25 cm</td> <td></td> </tr> </table> <p>When there is a delimitation strip between the performance area and the border:</p> <table style="width: 100%; border-collapse: collapse;"> <tr> <td style="width: 60%;">Width of the delimitation strip</td> <td style="width: 20%; text-align: center;">5 cm</td> <td style="width: 20%; text-align: right;">+/- 0,5 cm</td> </tr> </table> <p>The delimitation strip is part of the performance area.</p> <p>Performance area and border :</p> <ul style="list-style-type: none"> <li>- Equal elasticity on the surface as well as dampening.</li> <li>- When in use it should not have any motion energy.</li> <li>- Elasticity and dampening must be balanced in such a way that they guarantee the gymnast stability and freedom of movement. It must not restrict turns and slide movements.</li> <li>- The surface cover of the performance area must provide a balance between anti-skid and slippage. It must not cause skin burns.</li> <li>- The performance area must not produce disturbing sound during the execution of an exercise. It must assure a low noise level.</li> </ul>	Performance area	1300 x	1300 cm			Tolerance +/- 3 cm	Diagonals of the performance area:		1838 cm +/- 5cm	Border (25 + 25)		50 cm	Safety border		200 cm	Border as a variant			Horizontal Area, Width	25 cm		Slope max. 20 %, Width	25 cm		Width of the delimitation strip	5 cm	+/- 0,5 cm
Performance area	1300 x	1300 cm																										
		Tolerance +/- 3 cm																										
Diagonals of the performance area:		1838 cm +/- 5cm																										
Border (25 + 25)		50 cm																										
Safety border		200 cm																										
Border as a variant																												
Horizontal Area, Width	25 cm																											
Slope max. 20 %, Width	25 cm																											
Width of the delimitation strip	5 cm	+/- 0,5 cm																										
Colour	<p>Of plain colour which choice is left to the manufacturer's discretion. For certain events the FIG may stipulate the colours. The delimitation shall have a clear contrast to the performance area.</p>																											

Norms / Functional properties  
Regarding tests carried out by FIG Tests Institutes : please see chapter IV

<b>II</b>
<b>RG 1</b>
01.01.2011
<b>65</b>

Performance Area

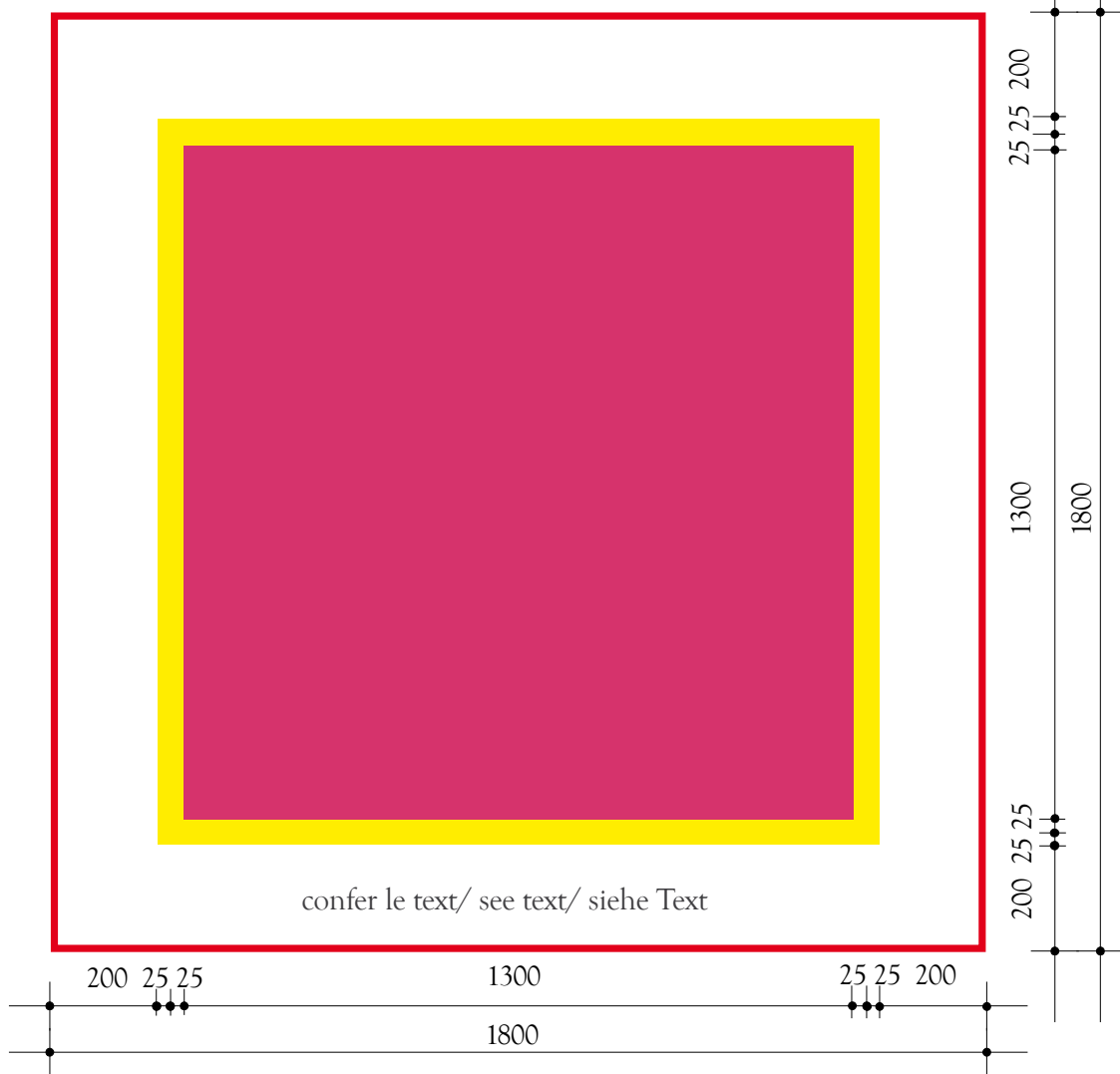

- surface de compétition, arena, Wettkampffläche
- cadre, edge, Umrandung
- zone de sécurité, safety zone, Sicherheitszone

variantes, profile - variants, Schnitt - Varianten A, B, C

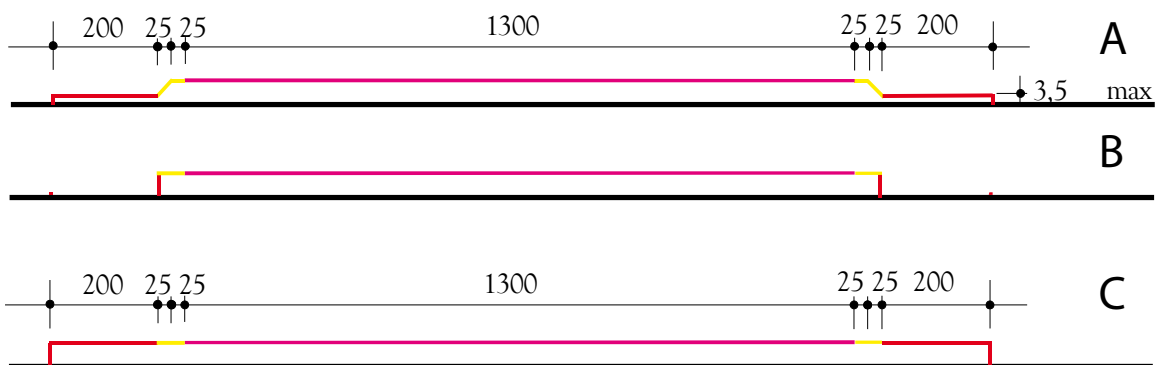

<b>II</b>
<b>RG 2-6</b>
01.01.2011
<b>66</b>

## Rope, Hoop, Ball, Clubs, Ribbon

Use • Rhythmic Gymnastics

### Construction / Description of material, measurements

RG 2 Rope	<p>Material: Hemp or similar suitable material</p> <p>Length: Optional (according to the height of the gymnast).</p> <p>Thickness: Uniform or reinforced in the centre.</p> <p>Shape: Both rope-ends, with or without knots. Without wooden handle. May be wrapped with a thin non-slip material in a length corresponding to the width of a hand.</p> <p>Colour: Optional. Bright colour preferred</p>
RG 3 Hoop	<p>Material: Wood or synthetics</p> <p>Weight: 300 g. minimum</p> <p>Inner diam.: 800 – 900 mm</p> <p>Colour: Optional. Bright colour preferred. Can be wrapped.</p>
RG 4 Ball	<p>Material: Rubber or soft plastic, antistatic</p> <p>Weight: 400 g. minimum</p> <p>Diameter: 180 – 200 mm</p> <p>Colour: Optional. Bright colour preferred.</p>
RG 5 Clubs	<p>Material: Wood or synthetics</p> <p>Length: 400 – 500 mm</p> <p>Weight: 150 g. min.</p> <p>Shape: Bottle shape</p> <p>Diameter of the head: 30 mm max.</p> <p>Colour: Optional. Bright colour preferred. Can be wrapped.</p>
RG 6 Gymnastic Ribbons	<p><i>Ribbon:</i></p> <p>Material: Satin or similar</p> <p>Material: Total length 7 m in one piece. The end at which the ribbon is attached to the cane is folded and doubled in a length of 1 meter. The ready-made ribbon has a total length of 6 meters, min. (5 meters, min for Juniors)</p> <p>Weight: 35 g. minimum, without the cane (30 g. min. for Juniors)</p> <p>Width: 40 – 60 mm</p> <p>Colour: Optional. Bright colour preferred. Can be wrapped.</p>
RG 6 Gymnastic Ribbons Cane	<p><i>Cane :</i></p> <p>Material: wood, bamboo, fibreglass or synthetics</p> <p>Length: 500 – 600 mm</p> <p>Diameter: maximum 10 mm at the thickest point.</p> <p>Shape: cylindric or conic. The handle may be wrapped in a thin anti-slip material with a length of 100 mm max.</p> <p>Colour: Optional</p> <p><i>Fixture :</i></p> <p>Material: cord, nylon-thread or similar item, or moveable ring resp. a swivel attached to the cane.</p> <p>Length: 70 mm maximum</p>

<b>II</b>
<b>RG 2, 3, 4</b>
<b>01.01.2006</b>
<b>67</b>

# Rope, Hoop, Ball

Maße in cm

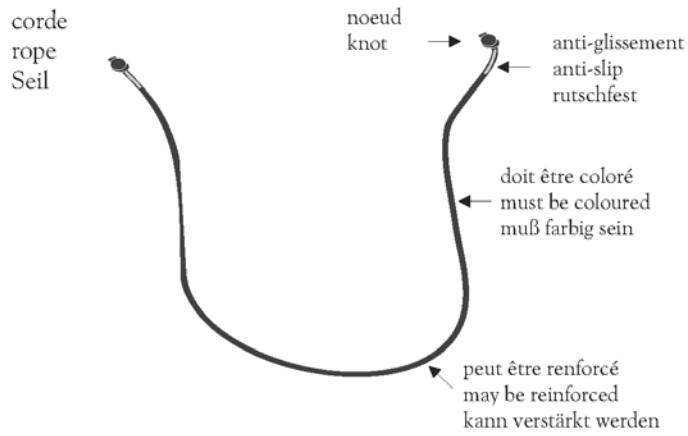

cerceau  
 hoop  
 Reifen

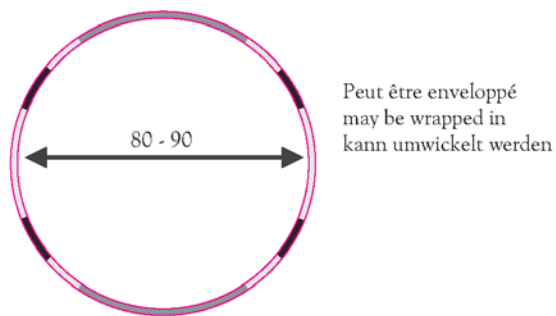

ballon  
 ball  
 Ball

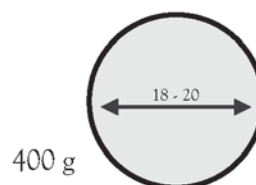

<b>II</b>
<b>RG 5, 6</b>
01.01.2011
<b>68</b>

## Clubs, Ribbon

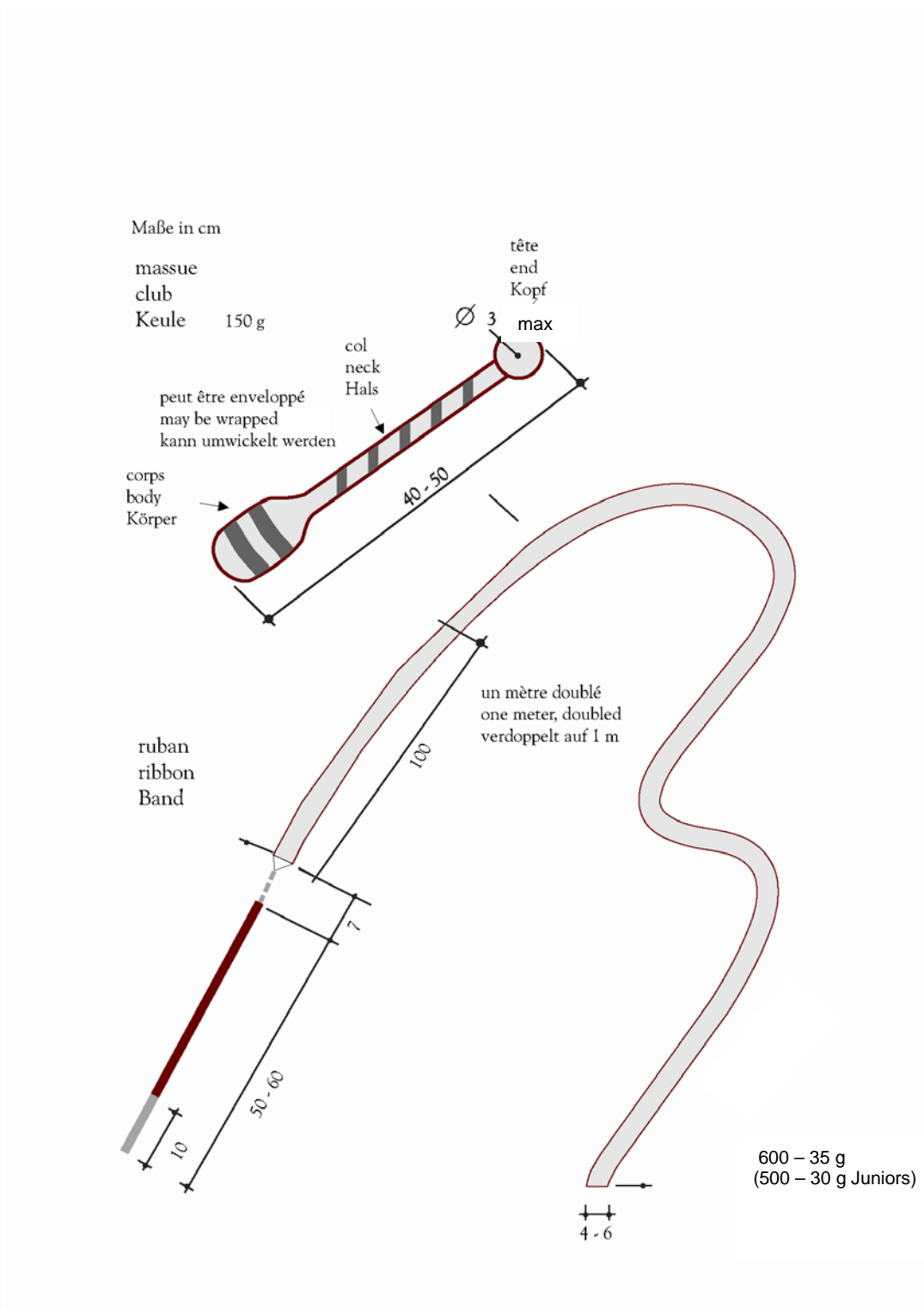

# Measurement Table for RG with Balance

<b>II</b>
<b>RG 10</b>
01.01.2011
<b>69</b>

Use • Rhythmic Gymnastics for testing prescriptions of RG 3,4,5,6

## Construction / Description of material, measurements

**Form** The apparatus consists of a table or a plate which can be placed on a table with special trays and tools for controlling prescribed parameters of RG equipment during the competition. An additional, suitable balance is needed.

**Measurements** The device should be suitable for measuring:

- Interior diameter of hoops (RG3) : 800 – 900mm
- diameter of balls (RG4) : 180 – 200mm
- diameter of the end of clubs (RG5) : 30mm max.
- diameter of the cane of gymnastic ribbons (RG6) : 10mm max.
  
- length of clubs (RG5) : 400 - 500mm
- length of ribbons (RG6) (Senior) : 6000mm min.  
[can be measured as 6 \* 1000mm]
- length of ribbons (RG6) (Junior) : 5000mm min.  
[can be measured as 5 \* 1000mm]
- length of the doubled part of ribbons (RG6) : 1000mm (+/- 50)
- length of the cane of gymnastic ribbons (RG6) : 500 - 600mm
- length of the optional handle part  
of the cane of gymnastic ribbons (RG6) : 100mm max.
- length of the fixture of gymnastic ribbons (RG6) : 70mm max.
- width of ribbons (RG6) : 40 - 60mm

The balance should be suitable for measuring the following weights ("masses") with a precision of +/- 1 g:

- hoops (RG3) : 300g min.
- balls (RG4) : 400g min.
- clubs (RG5) : 150g min.
- gymnastic ribbons without the cane (RG6, Seniors) : 35g min.
- gymnastic ribbons without the cane (RG6, Juniors) : 30g min.

The measurement trays for diameters of Hoops for measuring diameters shall control the whole circles, not only segments of the circles ("hoops shall not be bent during measurements"). Each Tray of 800mm & 900mm, must have a thickness minimum of 15mm.

All measures shall be indicated unmistakably on labels.

The weight of hoops shall be measured in a hanging position of the hoops.

# Measurement Table for RG with Balance

<b>II</b>
<b>RG 10</b>
01.01.2011
<b>70</b>

Example for positioning of trays and tools for controlling the prescribed parameters:

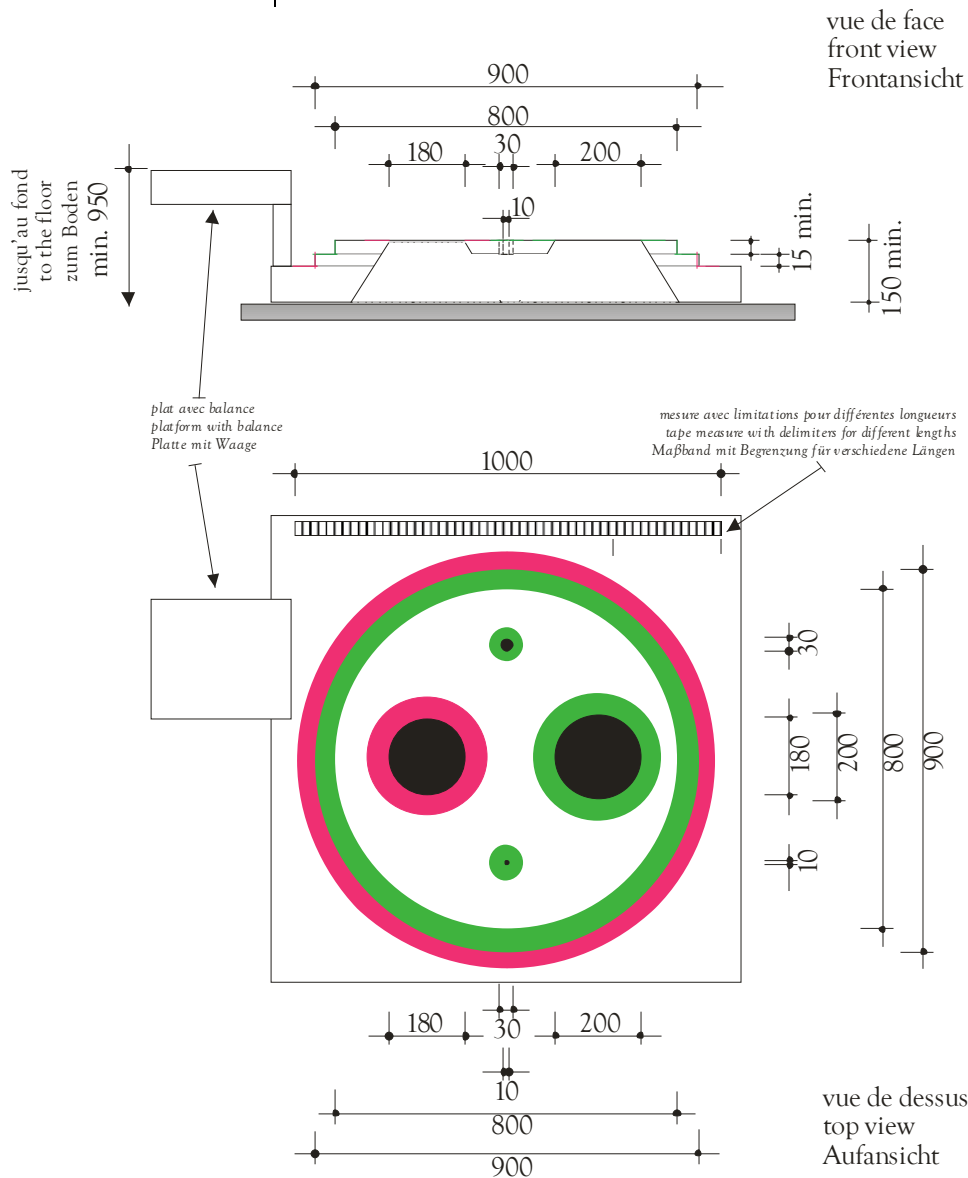

cotes obligatoires; construction selon le gré; dessin en exemple	dimensions: mandatory; design: at your discretion; drawing: typical example	Maße bindend; Konstruktion freigestellt; Zeichnung als Beispiel
--	---	---

II
AER
01.01.2009
71



## 2.4 AER Aerobic Gymnastics

## Performance Area

<b>II</b>
<b>AER 1</b>
01.01.2011
<b>72</b>

Use • Aerobic Gymnastics

### Construction / Description of material, measurements

Form	<p>The Performance Area shall have a square format. The surface must be horizontal, even and without gaps. Under load there shall not occur steps at the border of the plates.</p> <p>Border : Horizontal and even, at the same height as the performance area</p> <p>Safety zone: The safety zone shall be kept totally free as a surrounding zone around the performance area and the border. It shall be horizontal, even and without gaps.</p> <p>Delimitation strip: The competition area shall be surrounded by a black delimitation strip. The delimitation strip is part of the performance area.</p>														
Measurements	<table> <tr> <td>Performance area (Single)</td> <td>700 cm x 700 cm Tolerance +/- 3 cm</td> </tr> <tr> <td>Diagonals of the performance area:</td> <td>990 cm +/- 5cm</td> </tr> <tr> <td>Performance area (Duo, Trio, Groups):</td> <td>1000 cm x 1000 cm Tolerance +/- 3 cm</td> </tr> <tr> <td>Diagonals of the performance area:</td> <td>1414 cm +/- 5cm</td> </tr> <tr> <td>Width of the black delimitation strip</td> <td>5 cm, Tolerance +/- 0,5 cm</td> </tr> <tr> <td>Border</td> <td>100 cm</td> </tr> <tr> <td>Safety border</td> <td>100 cm</td> </tr> </table>	Performance area (Single)	700 cm x 700 cm Tolerance +/- 3 cm	Diagonals of the performance area:	990 cm +/- 5cm	Performance area (Duo, Trio, Groups):	1000 cm x 1000 cm Tolerance +/- 3 cm	Diagonals of the performance area:	1414 cm +/- 5cm	Width of the black delimitation strip	5 cm, Tolerance +/- 0,5 cm	Border	100 cm	Safety border	100 cm
Performance area (Single)	700 cm x 700 cm Tolerance +/- 3 cm														
Diagonals of the performance area:	990 cm +/- 5cm														
Performance area (Duo, Trio, Groups):	1000 cm x 1000 cm Tolerance +/- 3 cm														
Diagonals of the performance area:	1414 cm +/- 5cm														
Width of the black delimitation strip	5 cm, Tolerance +/- 0,5 cm														
Border	100 cm														
Safety border	100 cm														
Material	Parquet flooring – laminate or synthetics.														
Functional Properties	<p>Performance area and border :</p> <ul style="list-style-type: none"> <li>- Equal elasticity and dampening.</li> <li>- When in use no unrequested counter movements shall occur.</li> <li>- Elasticity and dampening must be balanced in such a way that they guarantee the gymnast stability and freedom of movement. It must not restrict turns and slide movements.</li> <li>- The surface cover of the Performance area must provide a balance between anti-skid and slippage. It must not cause skin burns.</li> <li>- The floor must not produce disturbing sound during the execution of an exercise. It must assure a low noise level.</li> </ul>														
Colour	Bright wooden colour, not shiny. For certain events the FIG may stipulate the colours. The competition area shall be surrounded by a black delimitation strip.														

Norms / Functional properties  
Regarding tests carried out by FIG Tests Institutes : please see chapter IV

Performance Area

<b>II</b>
<b>AER 1</b>
01.01.2011
<b>73</b>

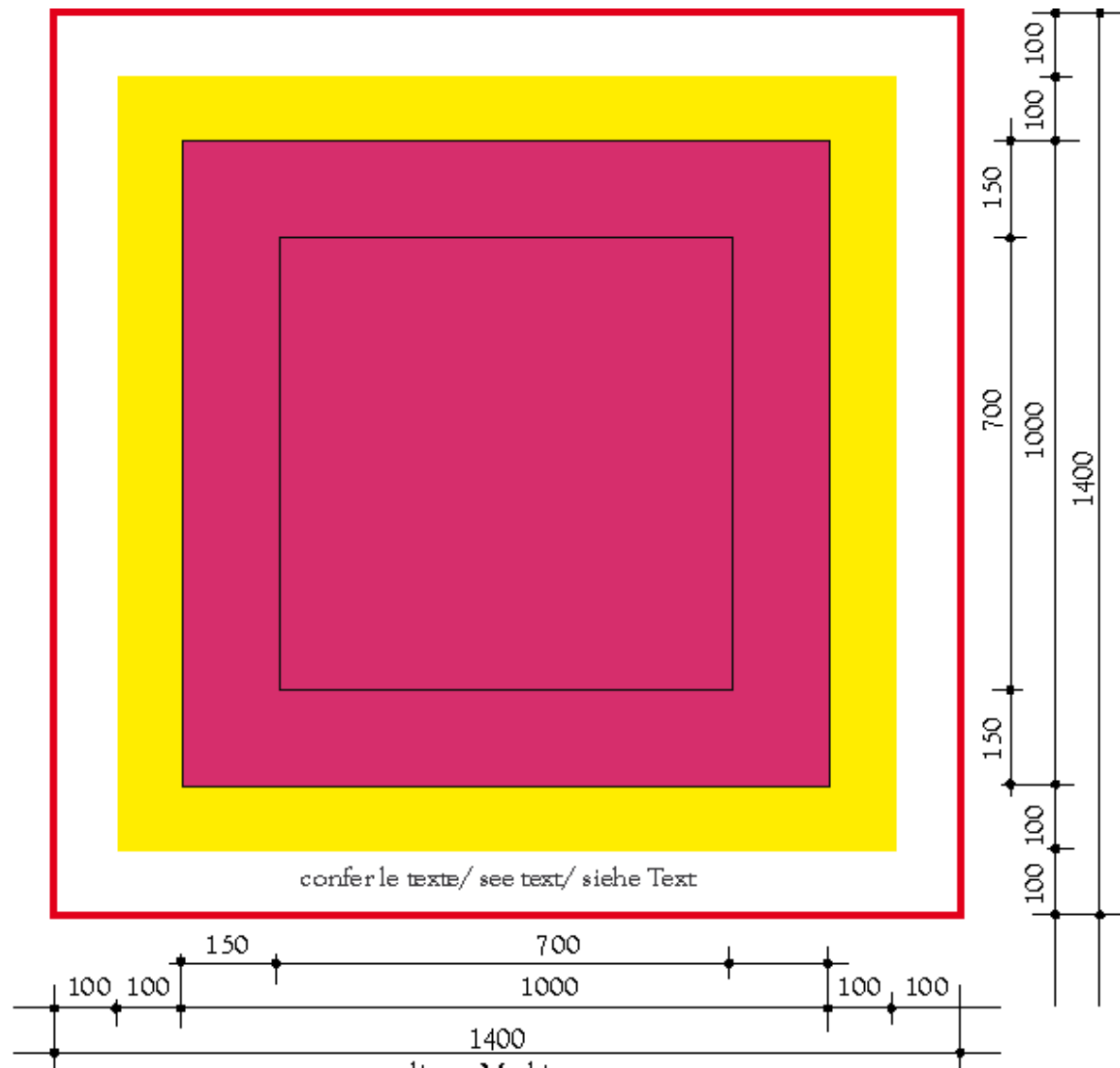

- marquage, line, Markierung
- surface de compétition, arena, Wettkampffläche
- cadre, edge, Umrandung
- zone de sécurité, safety zone, Sicherheitszone

variantes, profile - variants, Schnitt - Varianten A, B, C

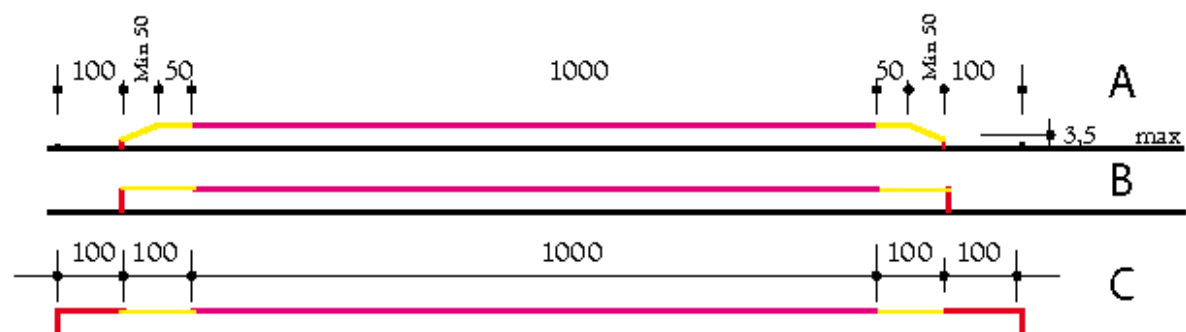



**VENTURELLI**  
M.A.D.E. FOR CHAMPIONS



**ELEGANT PERFORMANCE**

*Aliya Garaeva*

II
TRA
01.01.2011
75



## 2.5 TRA Trampoline Gymnastics

<b>II</b>
<b>TRA 1</b>
01.01.2011
<b>76</b>

# Trampoline

---

## 1. Frame

1.1. Interior measurements of the frame, with bed under tension, but without frame pads:

Length	505 cm	+/-6 cm
Width	291 cm	+/-5 cm
Height of bed (from floor)	115,5 cm	+/-0,5 cm

1.2.—For safety reasons the profile of the frame must have rounded edges. The radius must be min 15mm. The profile of the frame may also be oval or round, but in these cases, it must be guaranteed, that coaches are able to stand on the frame safely in order to give the necessary support to the athletes. Special attention must be given to the padding of the frame.

## 2. Trampoline Bed

2.1. Dimensions of the bed under tension ready for use, excluding attachment straps:

Length	428 cm	+/-6 cm
Width	214 cm	+/-5 cm

2.2. The bed must be constructed from light coloured bands, webs, strings etc., which must be held together in such a way that they are not displaced during use.

2.2.1. Web Construction:

Width of web under tension	0,55 cm +/- 0,15 cm
Distance between any two webs	1,6 cm (max.)

2.2.2. String Construction:

Width of strings under tension	0,3 cm +/- 0,1 cm
Distance between any two strings	no greater than 1 cm

2.3. The bed must be strong enough to withstand wear, and not tear when in use.

2.4. The jumping zone must be marked out clearly in red on the middle of the bed. The lines belong to the jumping zone.

Length	215 cm	+/- 4 cm
Width	108 cm	+/- 4 cm
The centre of the bed must be indicated by a red cross.		
Dimensions	70 cm	+/- 3 cm

## 3. Suspension

The bed must be suspended with springs in such a way as to present no danger to users. The tension on the bed should be such that the bed stabilises within a second after contact.

## 4. Area free of obstruction beneath the bed

The trampoline must be constructed so that the competitor will not touch any part of the frame beneath the bed.

## 5. Safety Padding

5.1. The frame and springs must be entirely covered by a shock absorbing padding, the thickness of which must be between 3,0 cm and 5,0 cm. The padding must not touch any part of the bed. The padding may extend over the bed by up to 3 cm, but the available unobstructed jumping area may not be smaller than the minimum bed size (422 cm x 209 cm).

5.2. The padding should be firmly fixed to the frame without hindering the normal action of the bed and springs. Nor should it cause noise through flapping.

5.3. The bottom of the padding, at the side of the bed, should not protrude above the level of the bed by more than 6 cm. The padding must be stable enough to allow a person to stand on it without protruding into the spaces between the springs.

<b>II</b>
<b>TRA 1</b>
01.01.2011
<b>77</b>

## Trampoline

---

### 6. Safety Platform

- 6.1. Platforms must be placed at both ends of the trampoline. The platform must be made of a framework which is firmly attached to the trampoline. The platforms must be constructed so that it is shock absorbent and the surface must be covered with a shock absorbing mat, firmly fixed to the platforms.

The mats must have the following dimensions:

Width:	300 cm	+/-2,5 cm
Length (including wedge, 40 cm)	240 cm	+/-2,5 cm
Thickness at the bedside	7,5 cm	+/-0,5 cm
Thickness at the end	20 cm	+/-2,0 cm

The platforms dimensions must be such, that the mats are sufficiently supported to ensure, that on landing, it supports the weight of the competitor without collapsing or folding.

The foam of the mats shall have a density of 25 kg / m<sup>3</sup> (+/-2,5 kg /m<sup>3</sup>). The ultimate tensile strength of the foam shall be ≥ 130 kPa, the compression stress value 40% shall be 4,0 (+/- 0.4) kPa

- 6.2. The mat covering the platform must extend to the edge of the bed (covering the springs).
- 6.3. The base of any Wheel stands must also be covered with padding.

### 7. Spotter mats

- 7.1. Spotter mats must be covered with a material which will slide easily. The foam of the spotter mats shall have a density of 20 kg / m<sup>3</sup> (+/-2 kg /m<sup>3</sup>). The ultimate tensile strength of the foam shall be ≥ 90 kPa, the compression stress value 40% shall be 2,5 (+/- 0.5) kPa

- 7.2. The mats must be provided with at least two handles or one long handle on the two long sides of the mat.

7.3. Dimensions:

Length	200 cm	- 50 cm
Width	150 cm	- 50 cm
Thickness	15 cm	- 5 cm

8. Safety mats on the ground: Mats shall rest on the ground around and between the trampolines for safety reasons. All mats shall be of the same height and type. One of the following two types shall be used:

a) Mats which satisfy the specifications of MAG11/WAG11/TRA11. (measures: Height: 20 cm, Width: 200cm, Tolerance: +/- 1 cm).

b) Mats with a core which shall have a density of 25 kg / m<sup>3</sup> (+/-2,5 kg /m<sup>3</sup>). The ultimate tensile strength of the foam shall be ≥ 130 kPa, the compression stress value 40% shall be 4,0 (+/- 0.4) kPa. Ultimate tensile strength of the cover material shall be 560-600 kPa. (measures: Height: 20 cm min , Width: 200cm, Tolerance: +/- 1 cm).

II
TRA 1
01.01.2011
78

# Trampoline

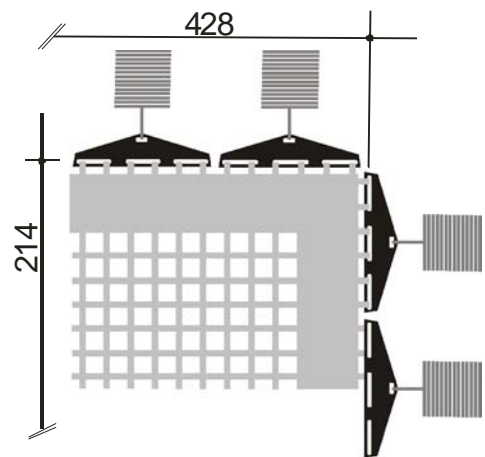
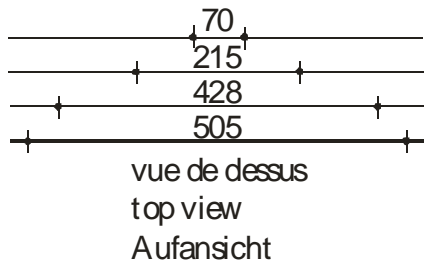
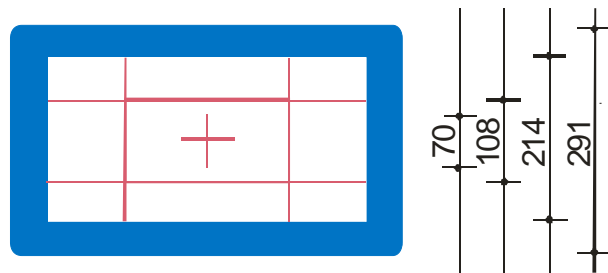
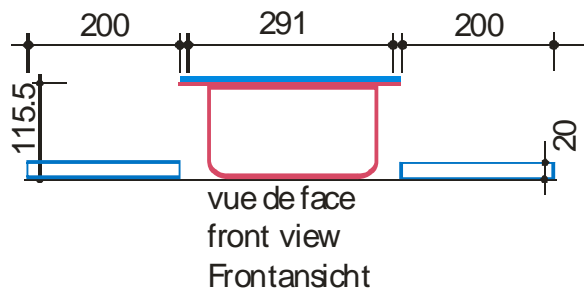
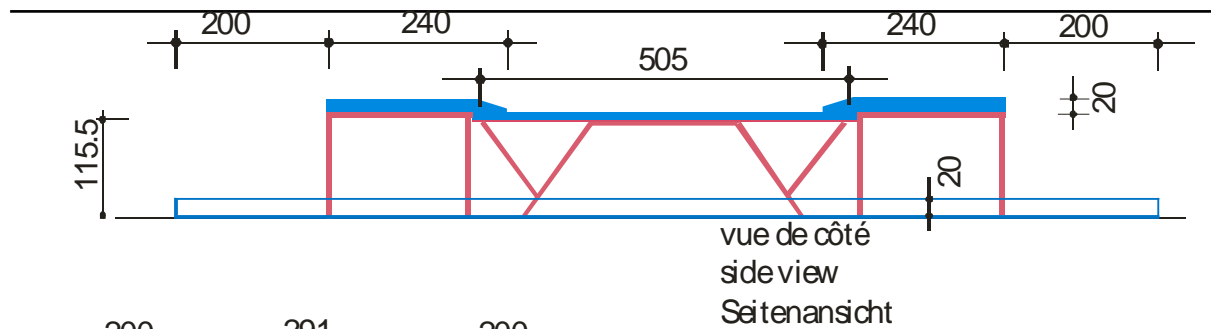

Délimitation de la toile  
boundary for the bed  
Begrenzung Tuch

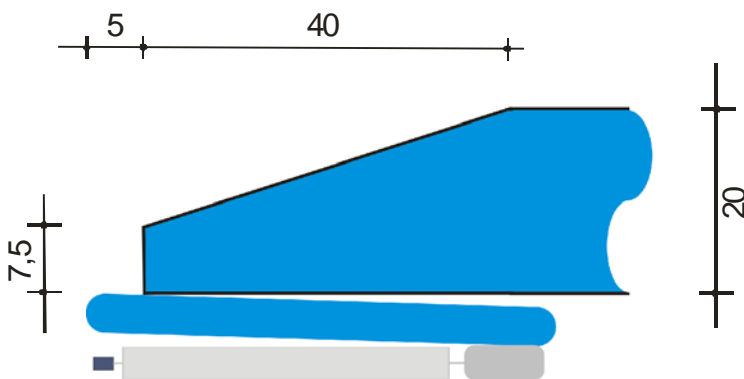

Detail  
Tapis sur la plateforme de sécurité  
mat covering the platform  
Matte auf Sicherheitsplattform

cotes obligatoires;  
construction selon le gré;  
dessin en exemple

dimensions: mandatory;  
design: at your discretion;  
drawing: typical example

Maße bindend;  
Konstruktion freigestellt;  
Zeichnung als Beispiel

<b>II</b>
<b>TRA 2</b>
01.01.2011
<b>79</b>

## Double Mini - Trampoline

---

### 1. Frame

- 1.1. For safety reasons no metal bars or other firm fixings are allowed across the ends of the Double Mini-Tramp other than at floor level.
- 1.2. For safety reasons the profile of the frame must have rounded edges. The radius must be minimum 15mm.
- 1.3. Safety Padding
  - 1.3.1. The frame and springs must be entirely covered by shock absorbing padding, the maximum Thickness of which must not be greater than 55mm. The padding must not cover any part of the bed.
  - 1.3.2. The padding should be firmly fixed to the frame without hindering the normal action of the bed and the springs. Nor should it cause noise through flapping.
  - 1.3.3. The bottom of the padding at the side of the bed should not protrude above the level of the bed by more than 6 cm.
  - 1.3.4. The bars beneath the bed must be padded.
  - 1.3.5. The frame ends on the dismount end must be covered with at least 50mm pads firmly joined together with the other padding.

### 2. Bed

- 2.1. The bed must be constructed from light coloured bands, webs, strings etc., which must be held together in such a way that they are not displaced during use.
- 2.2. Dimensions of the bed under tension, excluding attachment straps:
 

Length	285 cm	+/- 5 cm
Width	92 cm	+/- 1 cm
- 2.3. Height of bed from floor under tension:
 

Mounting End	45 cm	+/- 10 cm
Dismounting End	70 cm	+/- 10 cm
- 2.4. Width of web under tension: 0,4 cm min. 1,3 cm max.  
 Width of strings under tension: 0,3 cm +/- 0,1 cm
- 2.5. The strands of webbing (or string) must be sewn together, and the distance between any two strands must not be greater than 1,8 cm (max: 1 cm with string-construction).
- 2.6. The bed must be strong enough to withstand wear, and not tear when in use.
- 2.7. The Penalty Zones must be marked in red on the bed.  
 The dimensions of these zones are:
 

End markers	13 cm	+/- 2 cm
Centre zone	39 cm	+/- 1 cm
Distance of the Centre Zone (Measured from the mounting end)	90 cm	+/- 2 cm

<b>II</b>
<b>TRA 2</b>
01.01.2011
<b>80</b>

## Double Mini - Trampoline

### 3. Landing Area

- 3.1. The landing area shall be covered with a landing mat (TRA11) which is shock absorbent and which allows a stable landing on the feet.

Dimensions of the landing area must be:

Length (landing mat, TRA11)	600 cm	+/- 1 cm
Width (landing mat, TRA11)	300 cm	+/- 1 cm
Thickness (landing mat, TRA 11)	30 cm	+/- 1 cm

- 3.2. Additional safety mat behind the landing area

An additional safety mat with the minimum dimensions of 300 \* 200 \* 20 cm must be placed directly behind the landing area.

- 3.3. Landing Zones

Two landing zones must be marked out in the landing area, with either the whole zone in a contrasting colour or, with lines 50mm wide in a contrasting colour. If lines are used, they have to belong to their zones.

- 3.3.1. Landing Zone C:

The size of landing zone C is identical to the size of the Landing Area (see 3.1 above)

- 3.3.2. Landing Zone B:

The outer edge of the landing zone (or lines) marks the boundary of the landing zone, the dimensions of which must be:

Length	400 cm +/- 1 cm
Width	200 cm +/- 1 cm

- 3.3.3. Landing Zone A:

The outer edge of the landing zone (or lines) marks the boundary of the landing zone, the dimensions of which must be:

Length	200 cm +/- 1 cm
Width	100 cm +/- 1 cm

For certain events the FIG may stipulate the colours of the different zones.

### 4. Run-up

Floor mats shall be used on the run-up:

Length	2000 cm	+ 250 cm
Minimum Width	100 cm	
Thickness	2,5 cm	+/-0,5 cm

### 5. Spotter mats

- 5.1. Spotter mats must be covered with a material which will slide easily. The foam of the spotter mats shall have a density of 20 kg / m<sup>3</sup> (+/-2 kg /m<sup>3</sup>). The ultimate tensile strength of the foam shall be ≥ 90 kPa, the compression stress value 40% shall be 2,5 (+/- 0.5) kPa

- 5.2. The mats must be provided with at least two handles or one long handle on the two long sides of the mat.

- 5.3. Dimensions:-

Length	200 cm	- 50 cm
Width	150 cm	- 50 cm
Thickness	15 cm	- 5 cm

6. Safety mats on the ground: On the two sides of the DMT a mat shall rest on the ground for safety reasons (measures: Height: 20 cm, Width: 200cm, Tolerance: +/- 1 cm). They have to satisfy the specifications of MAG11/WAG11/TRA11.

7. No testing procedures for Double Mini-Trampolines at a test institute are available at the moment. The test must be performed by a federation who qualified with a team for the Men's Team Final in Double Mini-Trampoline at the last held World Championships. Further Procedures for Certification see Part III, 4.1. and 4.2.

II
TRA 2
01.01.2011
81

# Double Mini - Trampoline

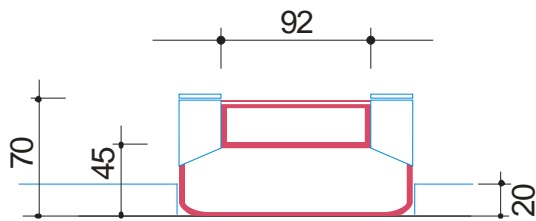

vue de face  
front view  
Frontansicht

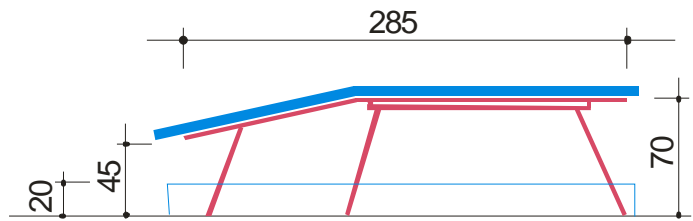

vue de côté  
side view  
Seitenansicht

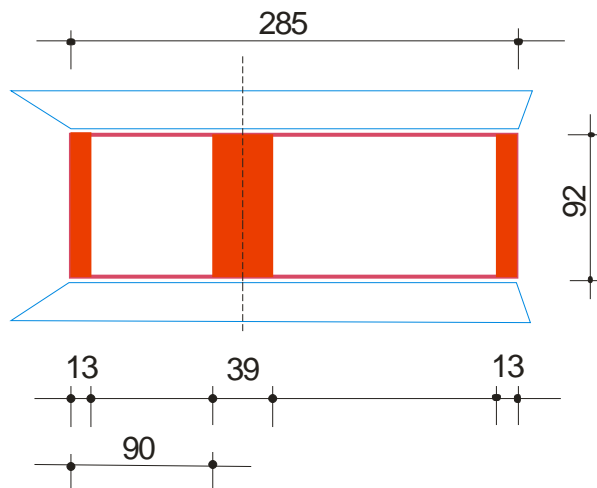

vue de dessus  
top view  
Aufansicht

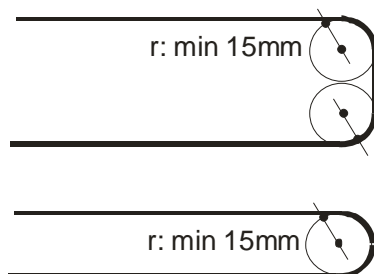

Variantes - détail profil du cadre  
variants - detail profile of the frame  
Varianten - Detail Rahmenprofil

cotes obligatoires;  
construction selon le gré;  
dessin en exemple

dimensions: mandatory;  
design: at your discretion;  
drawing typical example

Maße bindend;  
Konstruktion freigestellt;  
Zeichnung als Beispiel

II
TRA 2
01.01.2011
82

# Double Mini - Trampoline

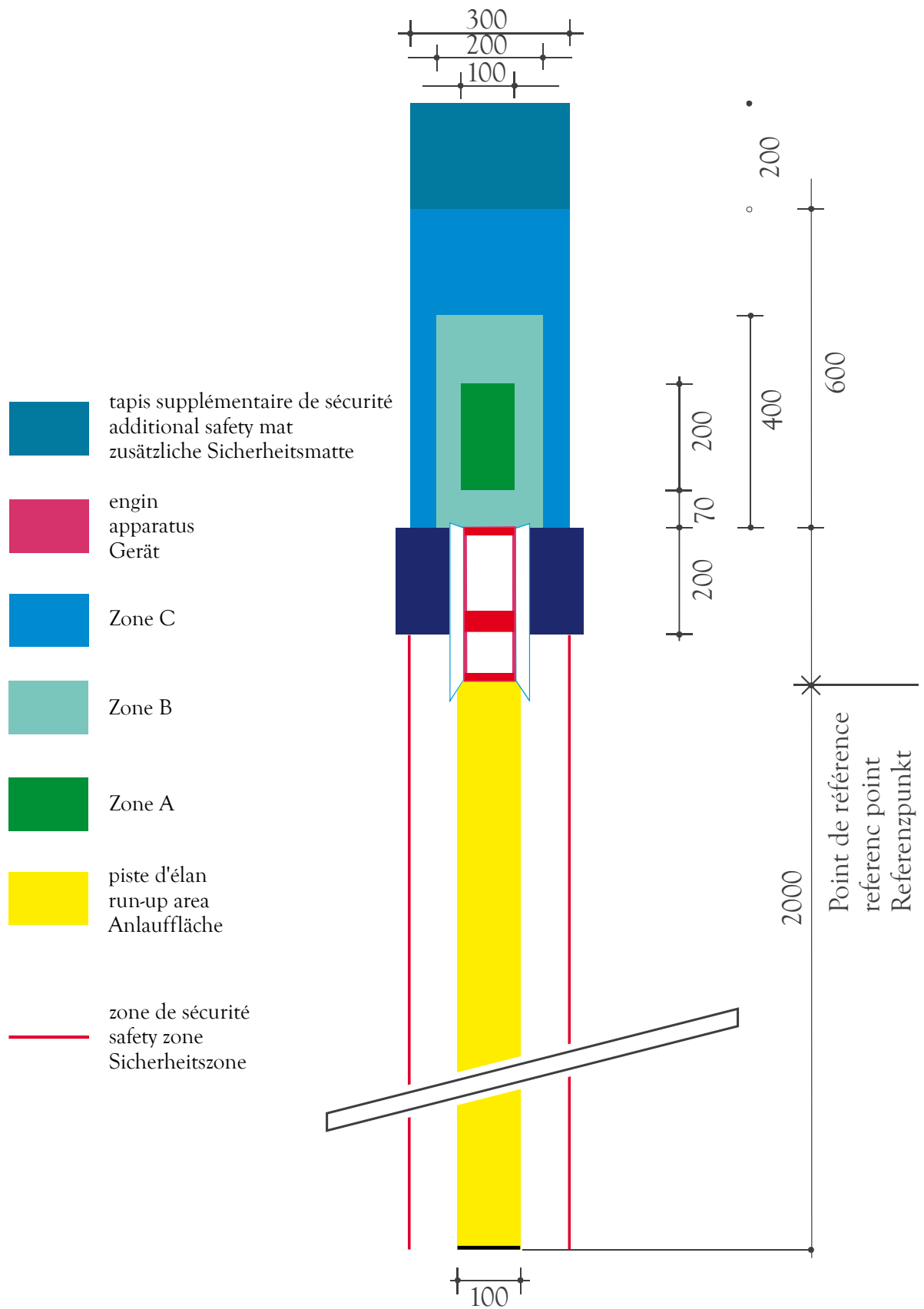

<b>II</b>
<b>TRA 3</b>
01.01.2011
<b>83</b>

## Tumbling track

---

### 1. Tumbling Track

- 1.1. The tumbling track must be constructed with a sprung surface, which must be padded. If constructed of several units these must be firmly fixed together as so not to separate in use and showing no space between them.

Dimension:

Length	2500 cm	+ 100 cm
Height	30 cm max (from 1.1.2012: ± 1 cm)	
Width of construction	200 cm	± 5 cm

### 1.2. Markings

Two lines, 50mm wide in a contrasting colour must mark the outer edge (boundary) of the track.

Distance (incl. lines): 150 cm +/- 1 cm

A centre line, 5 cm wide, in a contrasting colour, must mark the centre line of the tumbling track.

### 2. Landing Area

- 2.1. The landing area shall be covered with a landing mat (TRA11) which is shock absorbent and which allows a stable landing on the feet. The height of the landing mat shall be equal to the height of the tumbling track.

Dimensions of the landing area must be:

Length (landing mat TRA11)	600 cm	+/- 1 cm
Width (landing mat TRA11)	300 cm	+/- 1 cm
Thickness (landing mat TRA11)	30 cm	+/- 1 cm

### 2.2. Additional safety mat behind the landing area

An additional safety mat with the minimum dimensions of 300 \* 200 \* 20 cm must be placed directly behind the landing area.

### 2.3. Landing Zone

A landing Zone must be marked out in the landing area, with either the whole zone in a contrasting colour or, with lines 50mm wide in a contrasting colour. The outer edge of the landing zone (or lines) marks the boundary of the landing zone, the dimensions of which must be:

Length	400 cm +/- 1 cm
Width	200 cm +/- 1 cm

A non compulsory supplementary mat in the same dimension as the landing zone can be used (TRA13). In this case the supplementary mat must be attachable to the landing mat (i.e. using Velcro). The colour of the supplementary mat must be in contrast to the landing mat and the tumbling track or with lines according to the description above.

3. There must be a run up area (same level as tumbling track) prior to the tumbling track.

Dimensions:

Length	1000 cm	+100 cm
Minimal width	100 cm	

4. There must be a hard and a soft Vaulting Board available which meets the specifications of TRA 14.

# Tumbling track

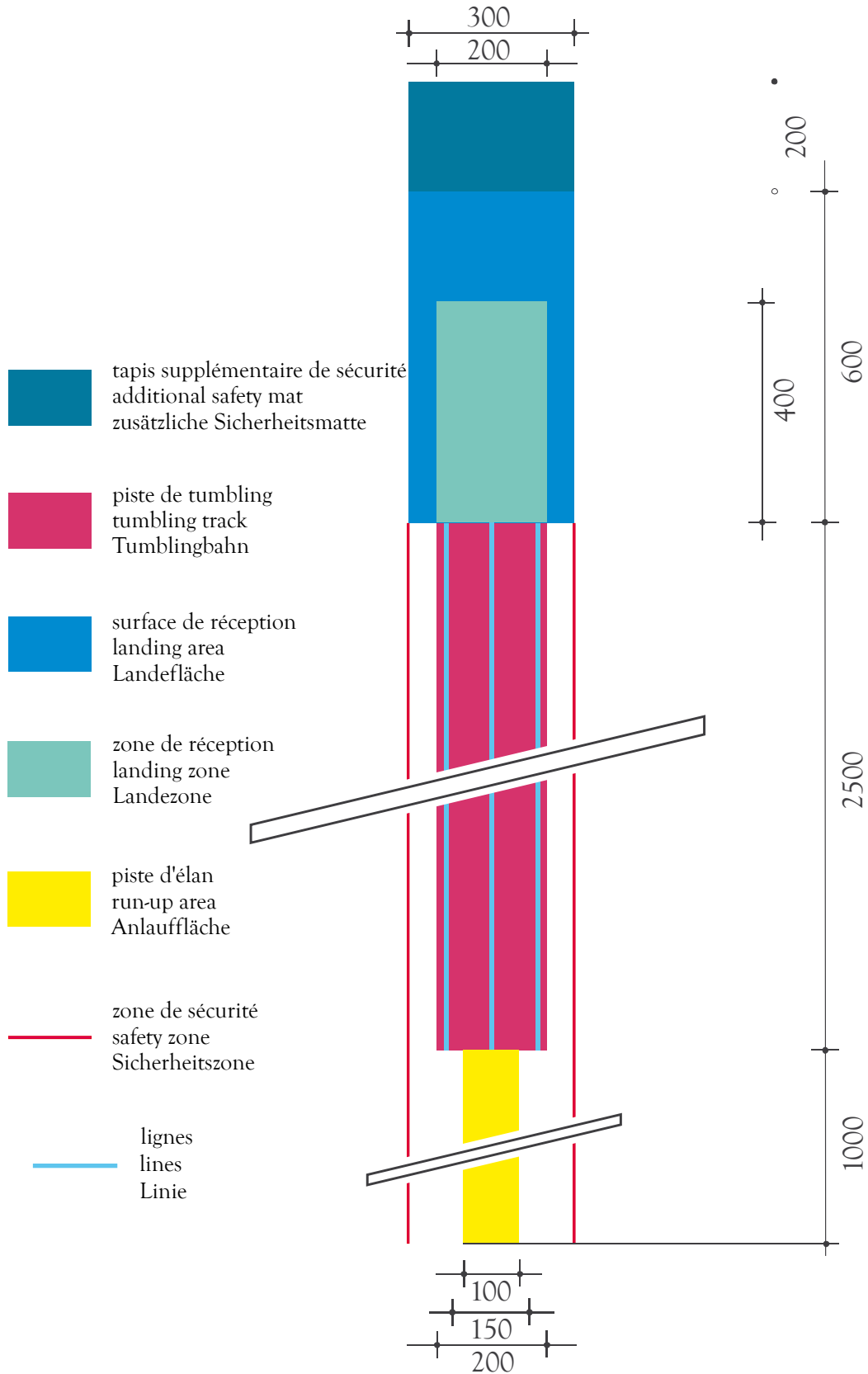

Landing mat  
 Double Mini-Trampoline + Tumbling  
 Safety mat  
 Trampoline, Double Mini-Trampoline

<b>II</b>
<b>TRA 11</b>
<b>01.01.2006</b>
<b>85</b>

Use • Double Mini-Trampoline; Tumbling; Trampoline

Construction / Description of material, measurements

Form	The surface must be horizontal, even and without gaps. To arrange the whole area several mats can be composed.
Measurements	Height safety mat Trampoline; DMT (TRA1, TRA2): 20 cm +/- 1 cm Height landing mat DMT; Tumbling (TRA2, TRA3): 30 cm +/- 1 cm
Functional Properties	<p>Absorbency:          The mats must absorb motion energy, in order to reduce the reaction transmitted to the body of the landing gymnast, to a tolerable proportion.</p> <p>They must respond to increased penetration with an evenly increasing resistance.</p> <p>Stability and Freedom of Movement :          Absorbency of the mats must be balanced in order to guarantee standing, walking stability and freedom of movement; there must be an equal balance between elasticity and absorbency properties.</p> <p>Indentations caused by the incidence of compressive forces must not encase the body parts, thereby hindering freedom of movements mainly of rolling a part of the body.</p> <p>If a cover is used, such cover may not cause any hindering folds. The mats' upper surface material must offer a balance between anti-slip and slippage. It must be neither slippery nor possess inhibitory resistance.</p> <p>By no means should mats be dislocated during performances. An anti-ski cover on the mats' underside may provide this condition.</p> <p>The border zones of the mats which are pushed together should practically have the same functional properties as the remaining surface. Impacts on the border zones should not cause different indentations than on the remaining surface. For this purpose, and to bridge joints, continuous runners are permitted.</p>
Colour	<p>Preference should be given to uniform colours.</p> <p>The upper surface must not show optically disturbing patterns or insignia.</p> <p>The FIG may designate the colour for certain events.</p>

Norms / Functional properties  
 Regarding tests carried out by FIG Tests Institutes : please see chapter IV

Supplementary mat  
Tumbling

<b>II</b>
<b>TRA 13</b>
<b>01.01.2009</b>
<b>86</b>

Use • Tumbling;

Construction / Description of material, measurements

Use	A supplementary mat must be available for the landing area in Tumbling. The usage is not compulsory.
Form	Their upper surface must be horizontal, even and without gaps. It shall have the size of the landing zone. The supplementary mat can be laid on the landing mats (TRA11), if used it must be attachable to the landing mat (i.e. using Velcro).
Measurements	<p>Height of the supplementary mat: 10 cm * 1 cm</p> <p>Surface: 400 x 200 cm * 1 cm</p> <p>* Tolerance +/-</p>
Functional Properties	<p>The foam of the supplementary mats shall have a density of 25 kg / m<sup>3</sup> (+/- 2 kg /m<sup>3</sup> ). The ultimate tensile strength of the foam shall be ≥ 115 kPa, the compression stress value 40% shall be 4,0 (+/- 0.5) kPa</p> <p>Their upper surface must be horizontal, even and without gaps. The supplementary mats have to be laid on the landing mats. The supplementary mat shall be attachable (i.e. using Velcro).</p>
Colour	<p>The colour of the supplementary mat must be in contrast to the landing mat and the tumbling track or with lines according to the description of the landing zone (see TRA3).</p> <p>The upper surface must not show optically disturbing patterns or insignia.</p> <p>The FIG may designate the colour for certain events.</p>

# Vaulting Board

<b>II</b>
<b>TRA14</b>
<b>01.01.2009</b>
<b>87</b>

Use • Tumbling “hard” and “soft”

## Construction / Description of material, measurements

### Form

The profile of the vaulting board must adhere exactly to the respective blue print.

Its upper surface rises in an arched form, approaching the horizontal between 75 cm and 95 cm, measured from the frontal angle. The height reached at this point, may not be exceeded. After this point, the upper surface may continue horizontally or slope downward.

The rise of the arch is 3.5 cm +/- 0,5 cm.

For competitions a “soft” and a “hard” vaulting board shall be available. The “hard” board shall be marked with a dot on the surface.

### Measurements

- Length	120 cm	* 1 cm
- Width	60 cm	* 1 cm
- Height	20 cm	* 1 cm
- Height (run-up side)	max 3 cm	
- Cushion Cover	2 cm	* 0,5 cm
- Total height with cushion cover	22 cm	* 1,5 cm
- Free space between floor and the lower edge of the vaulting board at the run-up side	max. 1 cm	

\*Tolerance +/-

The stipulated length and height refers to the vertical projection of the upper plate, i.e. the take-off plate.

The base may be larger, but cannot extend more than 2 cm beyond the projection of the board.

Labelling of the “hard” vaulting board on the surface by a dot with clear contrast on the longitudinal midline:

Distance to the side of run up	5 cm
Diameter	8 cm

### Functional Properties

The functional properties of the vaulting board (hardness, damping, elasticity) shall not be adjustable (i.e. springs must be fixed so that they cannot be easily removed by hand).

The elasticity of the vaulting board must be most effective in the area between 75 cm and 95 cm, measured horizontally from the frontal angle.

The vaulting-board must dampen the counter pressure, i.e. reduce motion energy.

Elasticity and absorbency must be evenly distributed, so that the effect of the vaulting board differs only slightly, regardless whether the force of the impact is at the middle axis, or away from it.

The upper surface of the vaulting board must offer slip resistance.

## Vaulting Board

<b>II</b>
<b>TRA14</b>
<b>01.01.2009</b>
<b>88</b>

### Colour

The board must not produce disturbing sounds during its use.

The board must not dislodge during use.

The vaulting board and its base may not have any sharp corners, edges and no protruding parts. Mainly the upper and under edge of the upper part of the Vaulting board towards the apparatus side (Vaulting Table, Balance Beam of Uneven Parallel Bars) shall be cushioned and rounded.

The choice of colour is left to the discretion of the manufacturer.

With exception of the dot for "hard" vaulting boards optically disturbing patterns, stripes or insignia on the upper surface are not permitted.

The FIG may designate the colour for certain events.

Norms / Functional properties  
Regarding tests carried out by FIG Tests Institutes : please see chapter IV

variante d'abaissement  
lowering variant  
Absenkungsvariante

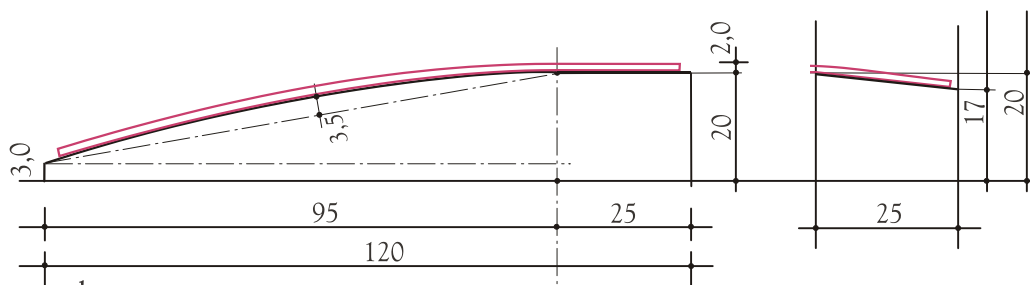

plan  
profile  
Schnitt

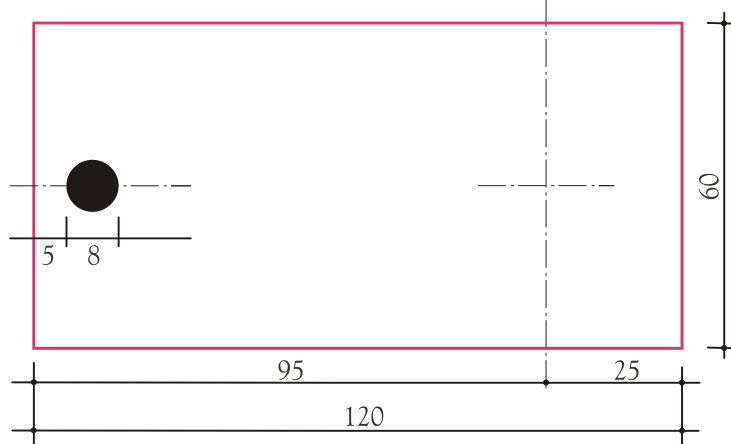

vue de dessus  
top view  
Aufsicht

Marcage pour tremplin dur  
mark for the hard board  
Markierung für hartes Brett

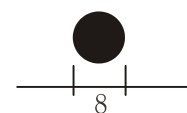

cotes obligatoires;  
construction selon le gré;  
dessin en exemple

dimensions: mandatory;  
design: at your discretion;  
drawing: typical example

Maße bindend;  
Konstruktion freigestellt;  
Zeichnung als Beispiel

Time measurement device for trampoline competitions  
- TMD

II
TRA 15
01.01.2011
90

- Use
- Helping device for judging individual and synchronized competitions

Construction / Description of material

General Requirements

The device must be able to measure deductions due to asynchronous landing in synchronized competitions as well as a sum of the flight times for the skills in individual competitions.

General Functions

1. Mode for synchronized competitions:  
The device is attached to the two trampolines which are used for the competition. It has to be administrated by a specialized judge who is responsible for the evaluation of the score of synchronization (S). After a "Start" during the flight phase of the first element the device shall register all time intervals between the landings of the gymnasts. After the end of the routine the device has to calculate, to indicate and to memorize the deductions for each skill and the total score for synchronization according to a conversion ratio between time intervals and deductions (TRA Code of Points).
2. Mode for individual competitions:  
The device is attached to the trampoline which is used for the competition. It has to be administrated by a specialized judge. After a "Start" during the flight phase of the first element the device shall register all time intervals between take-offs and the landings of the gymnast (flight times) including the flight time of the first element. At the end of the routine the device has to calculate, to indicate and to memorize the flight times of the elements as well as their sum (up to 10 skills).

Definitions

*Measurement Lines:* At least three parallel lines along the longitudinal side of the trampoline's bed. The lines are arranged  $\leq 100$  mm below the undersurface of the unloaded bed built-in a trampoline which is ready for use. One line shall be exactly below the middle of the jumping zone and at least two others are running in a distance of 540 ( $\pm 5$ )mm from the middle line of the bed directly below the lateral boundaries of the jumping zone (see drawing).

*Starting Point at Foot Contact:* The point in time of the first contact of the gymnast with at least one of the Measurement Lines by impacting on the trampoline's bed. At that time a measurable signal for the TMD shall be provoked.

*Ending Point at Foot Contact:* The point in time of the release of the gymnast from all Measurement Lines by taking off from the trampoline's bed. At that time a measurable signal for the TMD shall be provoked.

*Time Difference in Landing:* Time interval at the landing after the same synchronous jump between the Starting Point at Foot Contact of the first athlete and the Starting Point at Foot Contact of the partner, expressed in seconds rounded down to the next lower multiple of 0,005 s (e.g.: All values less than 0.005 s are rounded to 0.000 s, all values equal or higher than 0.005 s and less than 0.01 s are rounded to 0.005 s).

*Time of Flight:* Time interval during the flight phase of a jump between an Ending Point at Foot Contact and a succeeding Starting Point at Foot Contact, expressed in seconds rounded down to the next lower multiple of 0,005 s. (e.g.: All values less than 0.005 s are rounded to 0.000 s, all values equal or higher than 0.005 s and less than 0.01 s are rounded to 0.005 s).

Time measurement device for trampoline competitions  
- TMD

<b>II</b>
<b>TRA 15</b>
01.01.2011
<b>91</b>

**Total Time of Flight:** Sum of all measured Time of Flights during an exercise of an individual competition beginning with the first skill, expressed in seconds. This value in seconds is equivalent to the score for the total time of flight in points.

**Start:** The point in time fixed by a switch-key to be pressed by a specialized judge during the flight phase of the first element; from this time on the TMD records signals at landings of the athlete on the trampolines bed. For individual competitions the device has to remember the preceding Ending Point at Foot Contact to register the Time of Flight of the first element.

**Stop:** The point in time fixed by a switch-key to be pressed by a specialized judge, from this time on the TMD records no more signals at landings of the athlete on the trampoline's bed.

**Deduction for unsynchronized Landing:** Deduction in points for the synchronization of each element according to a conversion from the Time Difference in Landing according to the TRA Code of Points.

*Example 1: Calculation for the Deduction for an unsynchronized Landing with a factor of 2.5, rounded to 1/10 and a special treatment for less than 0.01 s (\*) and more than 0,20 s (\*\*) (TRA Code if points 2009):*

Time difference in landing (s)	Deduction (pts)
$0,00 \leq x < 0,01$	0,0 pts (*)
$0,01 \leq x < 0,06$	0,1 pts
$0,06 \leq x < 0,10$	0,2 pts
$0,10 \leq x < 0,14$	0,3 pts
$0,14 \leq x < 0,18$	0,4 pts
$0,18 \leq x \leq 0,20$	0,5 pts
if $x > 0,2$ then $x := 0,2$ s and deduction := 0,5 pts (**)	

(\*) special treatment for less than 0,01 s.

(\*\*) special treatment for more than 0,20 s.

**Sum of Deduction:** Accumulation of the Time Differences in Landing after each landing multiplied by 2,5 to give a total deduction rounded to 0,1 pts for all skills. As long as the unrounded sum is below 0,05 the corresponding sum of deduction shall be 0,0 pts. (\*\*\*) (see example 2)

**Synchronization Score:** The Synchronization Score should be shown as maximum 10,0 pts minus the Sum of deductions in case of 10 skills (see example 2). Otherwise the maximum score equals the number of the counted skills (for example 5,0 pts for 5 skills).

*Example 2: Calculation for the Sum of deduction and the Synchronization Score for a full exercise with 10 skills.*

Time differences in landing (s)	Acc.[rounded down] (s)	Sum of Deduction (pts)
		$0,00 \leq x < 0,05 \rightarrow 0,0$ pts (***)
1st skill	$x := 0,015$	0,015 $\rightarrow$ 0,0 pts (***)
2nd skill	$x := 0,035$	0,050 $\rightarrow$ 0,1 pts
3rd skill	$x := 0,120$	0,170 $\rightarrow$ 0,4 pts
4th skill	$x := 0,295$	0,370 (**) $\rightarrow$ 0,9 pts
5th skill	$x := 0,430$	0,570 (**) $\rightarrow$ 1,4 pts
6th skill	$x := 0,030$	0,600 $\rightarrow$ 1,5 pts
7th skill	$x := 0,005$	0,600 (*) $\rightarrow$ 1,5 pts
8th skill	$x := 0,115$	0,715 $\rightarrow$ 1,8 pts
9th skill	$x := 0,005$	0,715 (*) $\rightarrow$ 1,8 pts
10th skill	$x := 0,010$	0,725 $\rightarrow$ 1,8 pts
Sum of deduction :=		1,8 pts
Synchronization Score :=		8,2 pts

(\*) special treatment for less than 0,01 s.

(\*\*) special treatment for more than 0,20 s.

(\*\*\*) Deduction := 0,0 pts as long as the unrounded sum is below 0,05

Time measurement device for trampoline competitions  
- TMD

<b>II</b>
<b>TRA 15</b>
01.01.2011
<b>92</b>

Specific Requirements	<p>The device shall not interfere with the performance of the athletes nor shall it provoke any restriction of the functional properties of the trampoline. The detectors for the Starting and Ending Points at Foot Contact shall be installable at any standardized trampoline. The fixation shall be below the apparatus (trampoline with padding and safety platform) with no protruding parts. If there are cable connections, they must be long enough to reach the displacement specifications given for the "Arena for Trampoline Competitions" (see: Part II 4. Competition area; TRA). All other components of the device shall be out of the area of the safety mats on the ground. If emitters with optical beams are used, they shall not harm eyes of participants, judges, spectators or other staff. If emitters of radio waves are used, they shall not have a capacity of more than 0,01 watts in a frequency range of 27 megahertz and above. If the device needs external power, it must be provided with backup power, providing a battery life for at least 5 minutes after disconnecting the external power source. The system must provide time measurements with an error lower than <math>\pm 0,005</math> s. The TMD shall come with an English written documentation containing a user's guide and all necessary technical descriptions.</p>
Technical Features	<p>The control device shall contain a set of buttons, indicators and components with the following features:</p> <ul style="list-style-type: none"> <li>• SELECT MODE – individual or synchronized competition</li> <li>• RESET – Preparation for a new measurement</li> <li>• START– start the measurement of an exercise, indicated by a sound</li> <li>• STOP – stop the measurement of an exercise</li> <li>• VIEW – MODE – with the following possibilities: Synchronized competition mode: Selection for each skill (from 1 to 10) with the calculated Deductions for unsynchronized Landing as well as the Synchronization Score for the whole exercise. Individual competition mode: Selection for each skill (from 1 to 10) with the registered Times of Flight as well as the Total Time of Flight for the whole exercise.</li> <li>• Possibilities for a manual change of the Preliminary Synchronization Score with an increment of 0,2 points.</li> <li>• Components to ensure proper function of the sensors.</li> <li>• Components to indicate proper function of the power supply.</li> <li>• Connection devices and software to transfer all data to a personal computer using a standard method of data transmission (USB, Firewire etc.).</li> <li>• Software to memorize and print all data on a personal computer with the following details:             <ul style="list-style-type: none"> <li>- Time Differences in Landing and corresponding Deductions for unsynchronized Landing for all skills (from 1 to 10) as well as the Synchronization Score for the whole exercise for synchronized competitions.</li> <li>- Times of Flight for all skills (from 1 to 10) as well as the Total Time of Flight for the whole exercise for individual competitions.</li> </ul> </li> </ul>
Procedures for Approval	<p>The approval of a TMD shall include the following steps:</p> <ul style="list-style-type: none"> <li>- Confirmation by a member federation of the FIG (operation at a competition without technical problems; see: FIG Apparatus Norms Part III, clause 4.1).</li> <li>- Presentation at a testing institute (forwarding a full technical documentation written in English and the complete equipment, if necessary with a special adapter according to: FIG Apparatus Norms Part IV TRA15 - TMD)</li> </ul>

Time measurement device for trampoline competitions  
- TMD

<b>II</b>
<b>TRA 15</b>
01.01.2011
<b>93</b>

---

- Confirmation by a TC member ordered by the FIG-TC-TRA President about the functional status during a FIG competition  
With successful fulfillment of all procedures the certification shall be given by the General Secretary.

# EUROTRAMP®

## 50th Anniversary



[www.eurotramp.com](http://www.eurotramp.com)

II
ACRO
01.01.2006
95



## 2.6 ACRO Acrobatic Gymnastics

II
ACRO 1
01.01.2009
96

Floor

Use • Acrobatic Gymnastics

Construction / Description of material, measurements

Form	<p>The Performance Area shall have a square format. The surface must be horizontal, even and without gaps</p> <p>Border :</p> <p>Horizontal and even, at the same height of the performance area</p> <p>Border's variant :</p> <p>Width 50 cm, horizontal and even, at the same height of the performance area. The next 50 cm are inclined; the slope may not exceed 25%, max.</p> <p>Safety zone:</p> <p>The safety zone shall be kept totally free as a surrounding zone around the performance area and the border. It shall be horizontal, even and without gaps.</p>																				
Measurements	<table border="0"> <tr> <td>Performance area</td> <td>1200 cm x 1200 cm</td> </tr> <tr> <td></td> <td>Tolerance +/- 3 cm</td> </tr> <tr> <td>Diagonals of the performance area:</td> <td>1697 cm +/- 5cm</td> </tr> <tr> <td>Border</td> <td>100 cm, min.</td> </tr> <tr> <td>Border as a variant:</td> <td></td> </tr> <tr> <td>Horizontal area, Width</td> <td>50 cm, min.</td> </tr> <tr> <td>Slope max. 25 %, Width</td> <td>50 cm, min.</td> </tr> <tr> <td>Height of outer border at the very end</td> <td>3,5 cm, max.</td> </tr> </table> <p>When there is an delimitation strip between the performance area and the border :</p> <table border="0"> <tr> <td>Width of delimitation strip</td> <td>5 cm,</td> </tr> <tr> <td></td> <td>Tolerance +/- 0,5 cm</td> </tr> </table>	Performance area	1200 cm x 1200 cm		Tolerance +/- 3 cm	Diagonals of the performance area:	1697 cm +/- 5cm	Border	100 cm, min.	Border as a variant:		Horizontal area, Width	50 cm, min.	Slope max. 25 %, Width	50 cm, min.	Height of outer border at the very end	3,5 cm, max.	Width of delimitation strip	5 cm,		Tolerance +/- 0,5 cm
Performance area	1200 cm x 1200 cm																				
	Tolerance +/- 3 cm																				
Diagonals of the performance area:	1697 cm +/- 5cm																				
Border	100 cm, min.																				
Border as a variant:																					
Horizontal area, Width	50 cm, min.																				
Slope max. 25 %, Width	50 cm, min.																				
Height of outer border at the very end	3,5 cm, max.																				
Width of delimitation strip	5 cm,																				
	Tolerance +/- 0,5 cm																				
Functional Properties	<p>Performance area and border :</p> <ul style="list-style-type: none"> <li>- Equal elasticity on the surface as well as dampening.</li> <li>- When in use it should not have any disturbing motion energy.</li> <li>- Elasticity and dampening must be balanced in such a way that they guarantee the gymnast stability and freedom of movement. It must not restrict turns and slide movements.</li> <li>- The surface cover of the Performance area must provide a balance between anti-skid and slippage. It must not cause skin burns.</li> <li>- The floor must not produce disturbing sound during the execution of an exercise. It must assure a low noise level.</li> </ul>																				
Colour	<p>Of plain colour which choice is left to the manufacturer's discretion. For certain events the FIG may stipulate the colours. The delimitation shall have a clear contrast to the performance area.</p>																				
Delimitation Strip	<p>The delimitation strip is part of the performance area.</p>																				

<p>Norms / Functional properties Regarding tests carried out by FIG Tests Institutes: please see chapter IV</p>
---

II
ACRO 1
01.01.2009
97

Floor

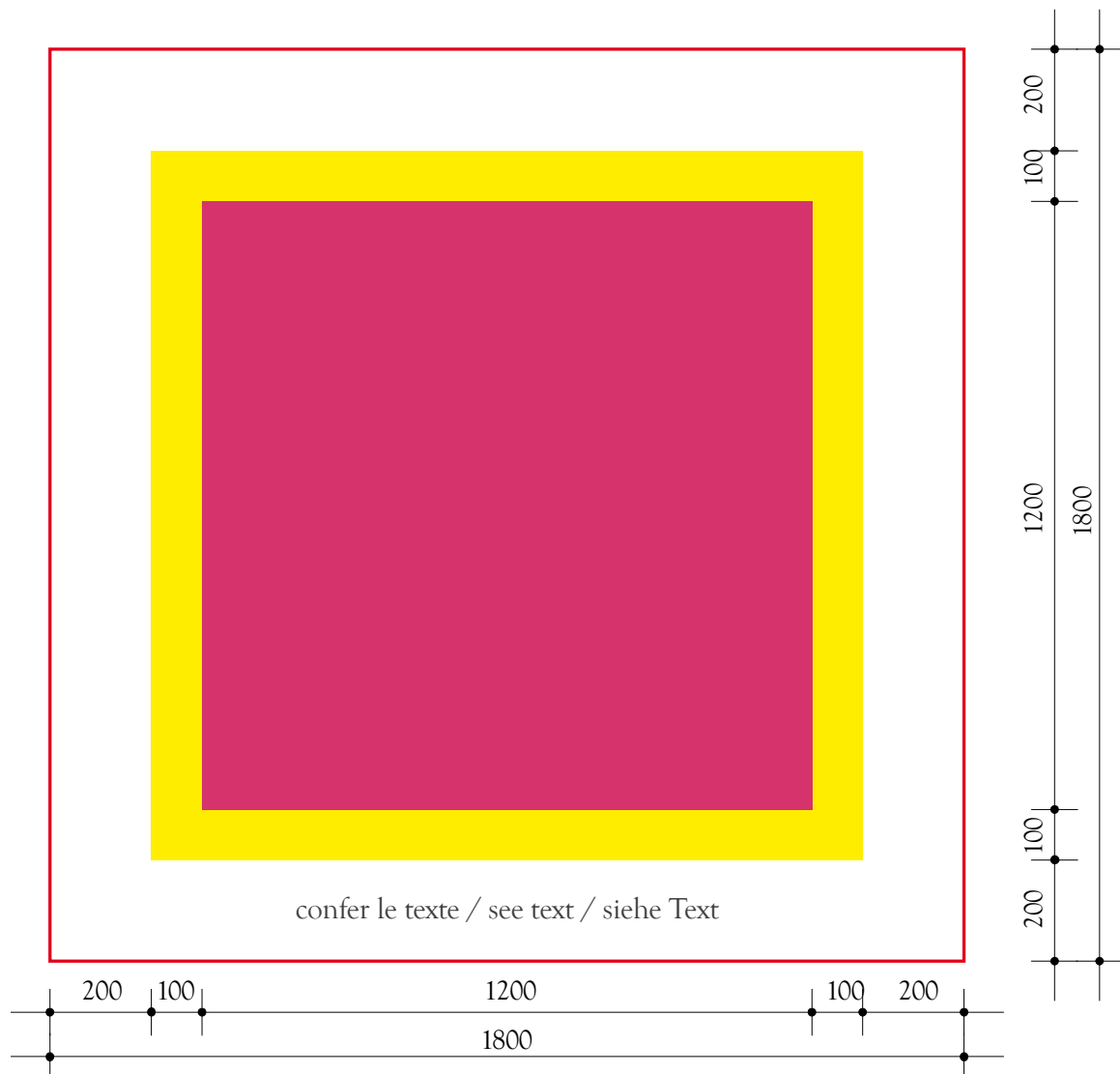

- surface de compétition, arena, Wettkampffläche
- cadre, edge, Umrandung
- zone de sécurité, safety zone, Sicherheitszone

variantes, profile - variants, Schnitt - Varianten A, B, C

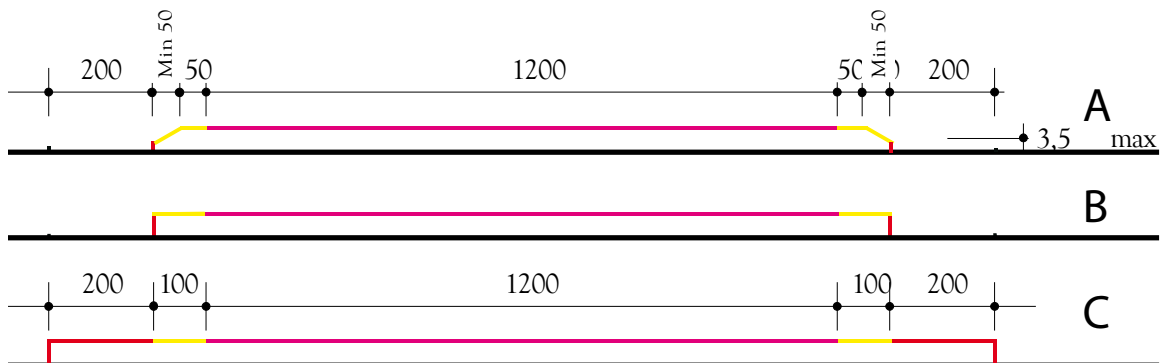

<b>II</b>
<b>ACRO 11</b>
<b>01.01.2006</b>
<b>98</b>

## Landing mat

---

Use      •      Acrobatic Gymnastics

---

### Construction / Description of material, measurements

---

Use	For landing a mat shall be available. The use is not compulsory.
Form and functional properties	The functional properties of the landing mat must be identical to those of the landing mats MAG 11 and WAG 11.
Measurements	The minimum size of the landing mat is 200 cm x 150 cm x 20 cm

---

Norms / Functional properties  
 Regarding tests carried out by FIG Tests Institutes: please see chapter IV

II
01.01.2009
99

3. Surfaces of apparatus, safety zones,  
total surfaces

<b>II</b>
<b>01.01.2009</b>
<b>100</b>

Discipline	Apparatus	Area Meters	Height of hall (prescription) if so from Podium min. Meters	Height of hall International Arena (recommended) if so from Podium min. Meters
MAG Men's Artistic Gymnastics	MAG 1 Floor	18.00 x 18.00	7.00	8.00 – 10.00
	MAG 2 Pommel Horse	4.00 x 4.00		
	MAG 3 Rings	6.00 x 6.00		
	MAG 4 Vaulting Table	5.00 x 35.00		
	MAG 5 Parallel Bars	6.00 x 12.00		
	MAG 6 Horizontal bar	6.00 x 12.00		
WAG Women's Artistic Gymnastics	WAG 1 Vaulting Table	5.00 x 35.00	6.00	8.00 – 10.00
	WAG 2 Uneven Bars	6.00 x 14.00		
	WAG 3 Balance Beam	6.00 x 18.00		
	WAG 4 Floor	18.00 x 18.00		
RG Rhythmic Gymnastics	RG 1 Performance area	18.00 x 18.00	8.00	10.00 – 12.00
AER Aerobic Gymnastics	AER 1 Performance area	18.00 x 18.00	6.00	8.00 – 10.00
TRA Trampoline Gymnastics	TRA 1 Trampoline (synch.)	15.00 x 15.00	8.00	10.00 – 12.00
	TRA 2 Double Mini Trampoline	5.00 x 35.00	6.00	8.00 – 10.00
	TRA 3 Tumbling Track	5.00 x 45.00	5.00	
ACRO Acrobatic Gymnastics	ACRO 1 Performance area	18.00 x 18.00	7.00	8.00 – 10.00

II
01.01.2009
101

#### 4. Competition area

Recommended Standards. For FIG Events the Placement of the Apparatuses and Podiums has to be approved by the FIG.

Arena – men's artistic gymnastics

II
MAG
01.01.2009
102

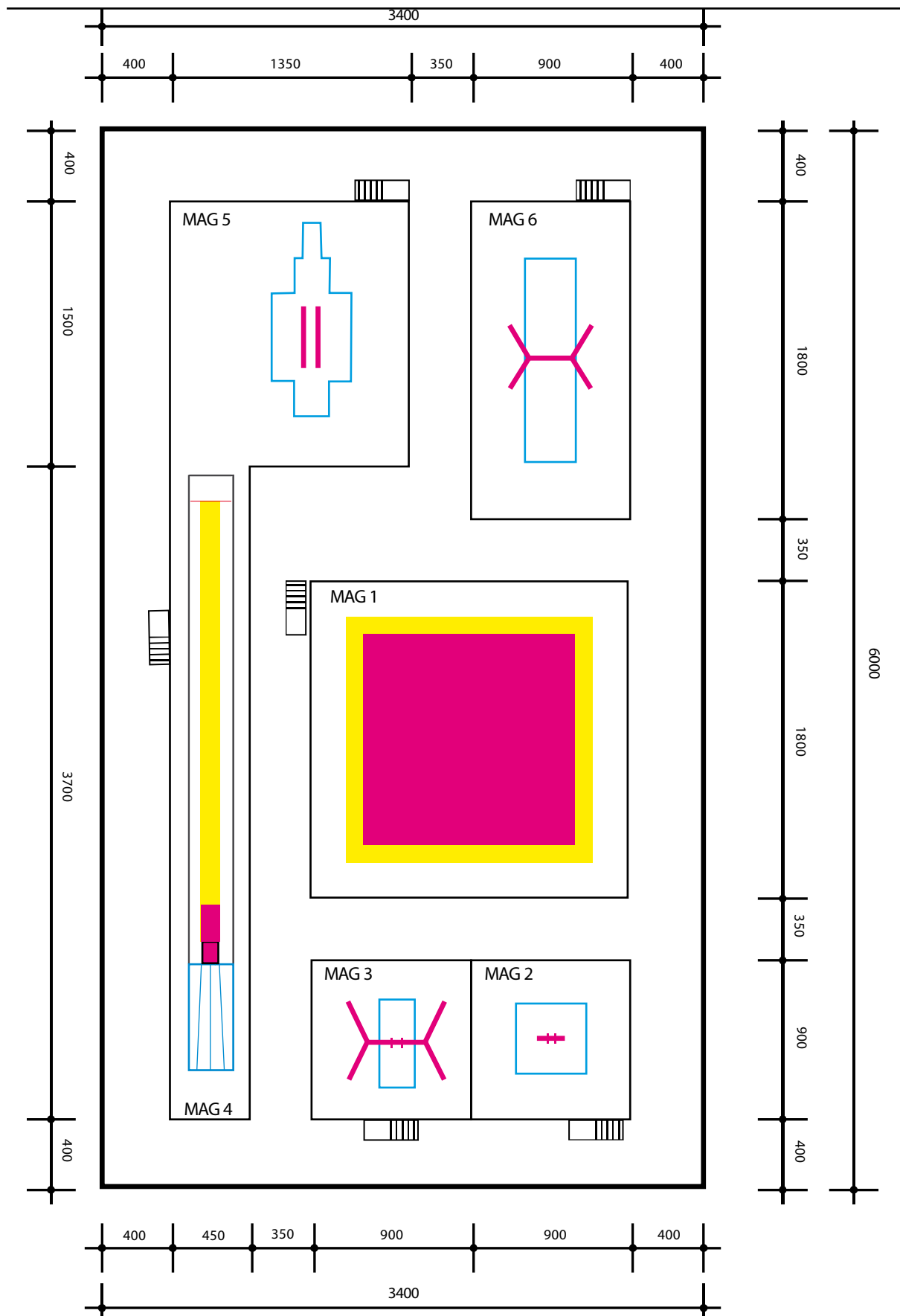

Arena – women’s artistic gymnastics

<b>II</b>
<b>WAG</b>
<b>01.01.2009</b>
<b>103</b>

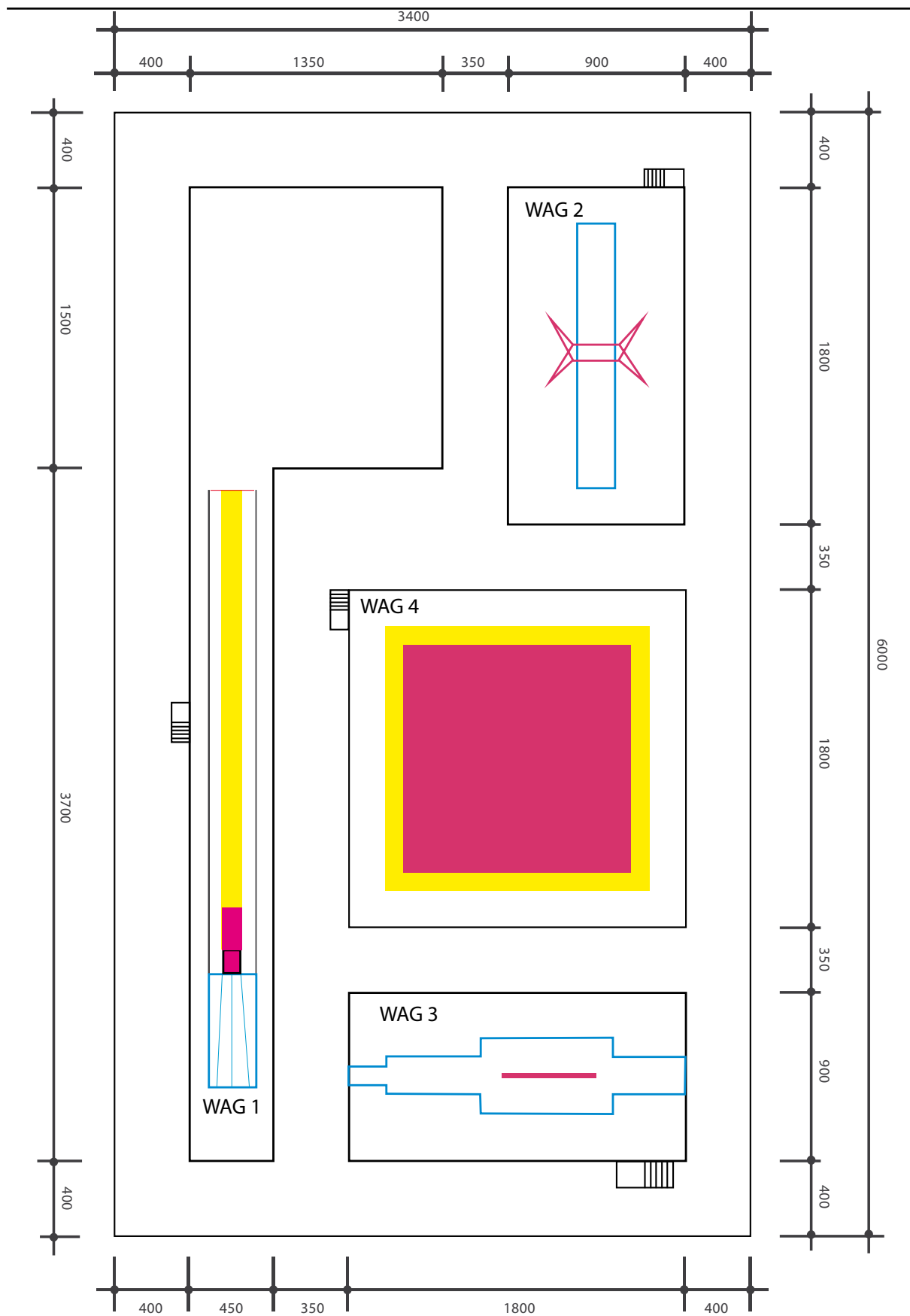

# Requirements for Podiums and Anchors at MAG and WAG Competitions

<b>II</b>
<b>MAG/WAG</b>
<b>01.01.2009</b>
<b>104</b>

## Construction / Measurements

Measurements	<p>Size of the podiums: See recommended standards on the proceeding pages.</p> <p>Height: 80 to 100 cm</p>
Requirements	<p>The podiums must be stable enough to withstand the forces which are transmitted by the gymnastics apparatuses.</p> <p>During competition no disturbing vibrations and movements shall occur in the podium.</p> <p>Special devices (i.e. additional, heavy supporting plates with sufficient area) should be used if the ground below the podiums is not hard enough.</p> <p>Additional columns shall be placed directly below the podium zones with high loads (i.e. below the stands of all gymnastics apparatuses).</p> <p>Floor anchors and equipment attachments )* on the ground shall be controlled by the local organizer of the competition before establishing the gymnastic equipment and podium. All attachments shall withstand a static force of 8000 N (+20N) in the pulling direction )**. This requirement must be fulfilled for both competition site and training sites.</p> <p>)* Equipment attachments are all devices which do not belong to the homologated standard parts of the apparatus (i.e. Horizontal bar, ring frame etc.)</p> <p>)** "pulling direction" means: The direction of the cable at a correctly mounted equipment. After the application of a static force as described for 1 min (+10s) in pulling direction, no permanent deformation shall be observed at the anchors and/or the equipment attachments.</p>

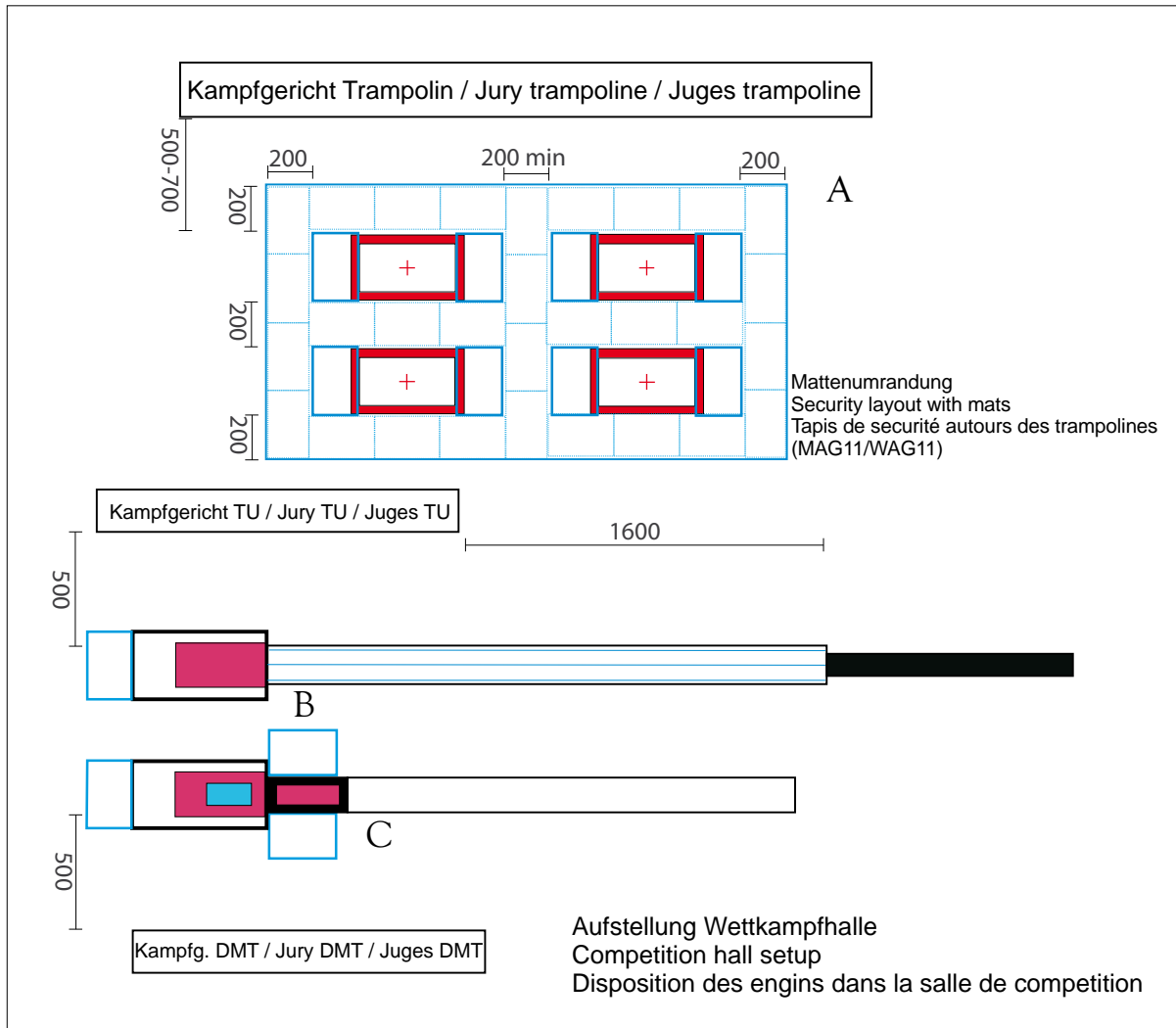

A      trampoline  
trampoline  
Trampolin

B      tumbling  
tumbling  
Tumbling

C      double mini-trampoline  
mini-double trampoline  
Doppelminitramp

*THE BEST FOR*  
**TOMORROW**



Official FIG Partner / Official RG Apparatus Supplier to Belarus

**Chacott**  
[www.chacott-jp.com](http://www.chacott-jp.com)

II
01.01.2011
107

---

5. Required Equipment for FIG - Competitions  
GAM/GAF/TRA

# Competition Equipment for men's artistic gymnastics

<b>II</b>
<b>MAG</b>
01.01.2011
<b>108</b>

		Quantity Arena	Quantity warm-up hall	Quantity for each training hall	Remarks
<b>For World Championships and Olympic Games</b>					
<b>Floor Exercise</b>					
Free exercise floor	MAG 1	1	1	1	
Magnesia stand for feet (filled with magesia)		2	2	2	
Magnesia stand for hands (filled with magnesia)		1	1	1	
Supplementary mat 200x200x10 cm			2	2	
<b>Pommel Horse</b>					
Pommel horse (including anchoring system to the floor)	MAG 2	1	2	2	
Set of landing mats 10 cm, surface according to Apparatus Norms	MAG 12	1	2	2	
Magnesia stand for hands (filled with magnesia)		1	2	2	
<b>Rings</b>					
Ring frame	MAG 3	1	1	1	
Set of landing mats 20 cm, surface according to Apparatus Norms	MAG 11	1	1	1	
Ring hook		1	1	1	
Magnesia stand for hands (filled with magnesia)		1	1	1	
Hard foam block approx. 90 x 50 x 70 cm for preparation of the rings		1	1	1	
Supplementary mat 200x200x10 cm			1	1	
<b>Vault</b>					
Vaulting table (including anchoring system to the floor and 20 cm high padding of the feet)	MAG 4	1	1	1	
Runway with clear markage block at 25 meters		1	1	1	
Set of landing mats 20 cm, surface according to Apparatus Norms	MAG 11	1	1	1	
Supplementary mat 600x200x10 cm with marked landing area (two diverging lines and one central line)	MAG 13	1	1	1	Compulsory use
Soft crash mat 300x200x30 cm			1	1	
Vaulting board 'hard' (with fixed springs)	MAG 14	1	1	1	
Vaulting board 'soft' (with fixed springs)	MAG 14	1	1	1	
Vaulting board Safety Collar	MAG 15	1	1	1	Compulsory use w ith round-off vaults
Mat for hands 120x100x3 cm	MAG 16	1	1	1	Use not compulsory
Tape measure 25 meters		1	1	1	
Magnesia stand for feet (filled with magesia)		1	1	1	
Magnesia stand for hands (filled with magnesia)		1	1	1	
<b>Parallel Bars</b>					
Parallel bars (if necessary with anchoring system to the floor / podium)	MAG 5	1	2	2	
Set of landing mats 20 cm, surface according to Apparatus Norms	MAG 11	1	2	2	
Vaulting board 'hard'	MAG 14	1	2	2	
Magnesia stand for hands (filled with magesia)		1	2	2	
Supplementary mat 200x200x10 cm			2	2	
<b>Horizontal Bar</b>					
Horizontal bar (including anchoring system to the floor)	MAG 6	1	1	1	
Set of landing mats 20 cm, surface according to Apparatus Norms	MAG 11	1	1	1	
Supplementary mat 400x200x10 cm	MAG 13	2	2	2	Compulsory use
Magnesia stand for hands (filled with magesia)		1	1	1	
Hard foam block, approx. 50x50x50 cm for preparation of rails		1	1	1	

Spare parts such as rails, vaulting boards, pommels etc. at the discretion of the Organiser

# Competition Equipment for women's artistic gymnastics

<b>II</b>
<b>WAG</b>
01.01.2011
<b>109</b>

<i>For World Championships and Olympic Games</i>	Quantity Arena	Quantity warm-up hall	Quantity for each training hall	Remarks	
<b>Vault</b>					
Vaulting table (including anchoring system to the floor and 20 cm high protection of the feet)	WAG 1	1	1	1	
Set of landing mats 20 cm, surface according to Apparatus Norms	WAG 11	1	1	1	
Runway with clear markage at 25 meters		1	1	1	
Supplementary mat 600x200x10 cm with marked landing area (two diverging lines and one central line)	WAG 13	1	1	1	Compulsory use
Soft crash mat 300x200x30 cm			1	1	
Vaulting board 'hard' (with fixed springs)	WAG 14	1	1	1	
Vaulting board 'soft' (with fixed springs)	WAG 14	1	1	1	
Vaulting board Safety Collar	WAG 15	1	1	1	Compulsory use with round-off vaults
Mat for hands 120x100x3 cm	WAG 16	1	1	1	Use not compulsory
Tape measure 25 meters		1	1	1	
Magnesia stand for feet (filled with magesia)		1	1	1	
Magnesia stand for hands (filled with magnesia)		1	1	1	
<b>Uneven Bars</b>					
Uneven bars	WAG 2	1	2	2	
10 cm support plates		1	1	1	
Set of landing mats 20 cm, surface according to Apparatus Norms	WAG 11	1	2	2	
Supplementary mat, 400x200x10 cm	WAG 13	1	2	2	compulsory use
Vaulting board 'soft' (with fixed springs)	WAG 14	1	2	2	
Magnesia stand for hands (filled with magesia)		1	2	2	
Hard foam block, approx. 50x50x50 cm for preparation of rails		1	2	2	
<b>Balance Beam</b>					
Balance beam with padded legs	WAG 3	1	2	2	All knobs and levers padded or removed
Set of landing mats 20 cm, surface according to Apparatus Norms	WAG 11	1	2	2	
Supplementary mat, 400x200x10 cm	WAG 13	1	2	2	Compulsory use
Vaulting board 'soft' (with fixed springs)	WAG 14	1	2	2	
Magnesia stand for hands (filled with magesia)		1	2	2	
<b>Floor Exercise</b>					
Free exercise floor	WAG 4	1	1	1	
Magnesia stand for feet (filled with magesia)		2	2	2	
Magnesia stand for hands (filled with magesia)		1	1	1	
Supplementary mat 200x200x10 cm			2	2	

Spare parts such as rails, vaulting board etc. at the discretion of the Organiser

Competition Equipment for Trampoline,  
Double Minitrampoline, Tumbling

<b>II</b>
<b>TRA</b>
01.01.2011
<b>110</b>

**For World Championships and Olympic Games**

		Quantity Arena	Quantity warm-up hall	Quantity for each training hall **	Remarks
<b>Trampoline</b>					
Trampolines	TRA 1	4	4	4	
Safety platforms (see TRA 1, Art. 6)		8	8	8	
Platform mats with wedges (see TRA 1, Art. 6)		8	8	8	
Stability plates *		16	16	16	
Spotter mats (see TRA 1, Art. 7)	TRA 12	4	4	4	
Safety mats on the ground (see TRA 1, Art. 8)	TRA 11	30	30	30	30 mats if 300x200x20 cm
Time Measurement Device	TRA 15	2 sets	2 sets *	2 sets *	
Magnesia stands (filled with magnesia)		2	2	2	
<b>Double Mini-Trampoline</b>					
Double Mini-Trampoline	TRA 2	1	1	1	
Run-up (see TRA 2, Art. 4)		1	1	1	
Spotter-mat (see TRA 2, Art. 5)	TRA 12	1	1	1	
Landing mats with marking of landing zones (see TRA 2, Art. 3)	TRA 11	1	1	1	
Additional safety mat 300x200x20 cm (see TRA 2, Art. 3.2)		1	1	1	Placement: behind the landing area
Safety mats besides the DMT (see TRA 2, Art. 6)	TRA 11	2	2	2	
Set of Safety mats (min. 50 cm wide; 5 cm thickness) *		1	1	1	Placement: around the landing area
Magnesia stands (filled with magnesia)		1	1	1	
<b>Tumbling</b>					
Tumbling track	TRA 3	1	1	1	
Run-up (see TRA 3, Art. 3)		1	1	1	
Landing mats with marking of landing zone (see TRA 3, Art. 2)	TRA 11	1	1	1	
Supplementary mat 400x200x10 cm	TRA 13	1	1	1	With marking of landing zone
Additional safety mat 300x200x20 cm (see TRA 3, Art. 2.2)		1	1	1	Placement: behind the landing area
Vaulting board 'hard'	TRA 14	1	1	1	
Vaulting board 'soft'	TRA 14	1	1	1	
Set of Safety mats (min. 50 cm wide; 5 cm thickness) *		1	1	1	Placement: around the landing area
Magnesia stands (filled with magnesia)		1	1	1	

\* = not compulsory

\*\* = if applicable

Spare parts at the discretion of the Organiser

II
01.01.2006
111

6. Training centres  
Auxiliary apparatus for training

The chapter II.6 will be available with the next edition.

<b>II</b>
<b>01.01.2006</b>
<b>112</b>

---

<b>01.01.2006</b>
<b>113</b>

---

## 7. Development of apparatus / tests

The chapter II.7 will be available with the next edition

Dream of Gymnastics

# SASAKI®

- Official Partner of F.I.G.
- Certified Supplier of Apparel and Apparatus for Japan Gymnastic Association
- Official Supplier for Bulgarian R.G. Federation



**SASAKI SPORTS INC.** 3-15-3 Ikejiri, Setagaya-ku, Tokyo 154-0001 Japan Tel. 81-3-3410-3391 Fax. 81-3-3410-3498

[www.sasaki-sports.co.jp](http://www.sasaki-sports.co.jp)

II
01.01.2006
115

8. Information regarding the apparatus used in Gymnastics for All

The chapter II.8 will be available with the next edition

<b>II</b>
<b>01.01.2006</b>
<b>116</b>

---



# **FÉDÉRATION INTERNATIONALE DE GYMNASTIQUE**

## **III Certificates and diplomas**

# CONTINENTAL



**Sole Suppliers  
of Gymnastic  
Equipment to the  
2010 European  
Championships -  
Birmingham**



Continental Sports Ltd, Paddock, Huddersfield, England HD1 4SD  
Tel: (01484) 542051 Fax: (01484) 539148  
Email: sales@contisports.co.uk

[www.continentalsports.co.uk](http://www.continentalsports.co.uk)

## Content

III
01.01.2011
1

	Page
1. Each apparatus must have a valid FIG Certificate	III/3
2. Validity of the Certificate	III/3
3. Rights of the Apparatus Manufacturer with a valid FIG Certificate	III/3
4. Procedure to obtain a Certificate	III/4
4.1 Practical Test	
4.2 Testing by an FIG recognised Testing Institute	
4.3 Recognition of the FIG Statutes, Rules and Regulations, Applicable law and arbitration, Code of Auto discipline	
4.4 Issuing of FIG Certificate	
5. Testing Fees of the FIG recognised Testing Institutes	III/6
6. Fee for the Certificates	III/6
7. FIG Diploma	III/6
8. Reward for the suppliers of World Championships and World Cup Finals	III/7
9. Renewal of Certificates	III/7
10. New Apparatus, Modified Apparatus, New Developments	III/7
11. Publication of the FIG Certificates and Diplomas	III/8
12. FIG Sticker - FIG APPROVED	III/8
13. Control of apparatus at the competitions Re-testing of apparatus by the FIG at the Testing Institute	III/8
14. FIG recognised Testing Institutes	III/9
15. Publicity and manufacturer's logo on apparatus	III/9
16. Waiver of Liability	III/9
17. Current Fees for FIG-Certificates	III/10
18. Code of Auto discipline	III/10

## Content

III
01.01.2011
2

Page

---

Appendix 1	Directives for the Use of Official FIG Designations and Logos	III/11
Appendix 2	FIG Recognised Testing Institutes Addresses and Contact Persons	III/15
Appendix 3	FIG Recognised Testing Institutes What can be tested where?	III/16
Appendix 4	Testing Fees of the FIG Recognised Testing Institutes	III/17
Appendix 5	Code of Auto discipline	III/19
Appendix 6	Intermediate Rules	III/27

III
01.01.2009
3

---

## 1. Each apparatus must have a valid FIG Certificate

The definition of «Apparatus» for these Apparatus Norms is:  
All apparatus used at FIG competitions and listed in these Apparatus Norms.

Each apparatus, including all hand apparatus used in Rhythmic Gymnastics, must have its own, valid Certificate, to be used at FIG events, Olympic Games, World Games and international events.

For Olympic Games, World Championships, World Games and other multi-sports games (e.g. Commonwealth Games, Asian Games, Panam Games, University Games), the apparatus must have a valid certificate at least 1 year prior to the competitions. For all other competitions, the certificates must be valid at the latest at the moment of the invitation. Example: World Cup / World Series competitions: 3 months prior to the competitions.

## 2. Validity of the Certificate

The Certificates have a validity of two years. The expiry date is indicated on the certificate.

The FIG may, at any time, prolong or shorten the validity of issued Certificates or withdraw a Certificate.

## 3. Rights of the Apparatus Manufacturer with a valid FIG Certificate

When receiving a FIG Certificate, the apparatus manufacturer obtains the following rights:

- The right that the respective apparatus may be used at all official events of the FIG, its Continental Unions and member federations, as well as at the Olympic Games and World Games.
- The right to use the designation and the logo «FIG Approved» together in the catalogue and other publicity material, as prescribed in the respective directives of the FIG. (see Appendix 1)
- The use of the sticker « FIG Approved » on the respective apparatus.
- The regular publication in the list of certified apparatus in the FIG Bulletin and on FIG's website.
- One free advertisement (1 x ½ page, black and white) in the FIG Bulletin during the period of validity of each Certificate.

III
01.01.2009
4

---

#### 4. Procedure to obtain an FIG Certificate

The procedure has four steps:

- Practical test
- Testing at one of the FIG recognised Testing Institutes
- Declaration to be bound by the FIG's Statutes, Rules and Regulations as well as the provisions concerning governing law and arbitration
- Issuing of the Certificate by the FIG

##### 4.1 Practical Test

Apparatus manufacturers who wish a Certificate must first have their apparatus tested practically by gymnasts and coaches. For this purpose, the manufacturer contacts directly one of FIG's member federations, which can test the apparatus in a training centre by elite gymnasts. The apparatus must be tested under competition conditions. The manufacturer must provide a confirmation signed by a member federation containing the following:

*«We confirm to have tested apparatus X under competition conditions at our training centre and/or at competitions. The apparatus is of the best quality, safe and suitable to be used at international competitions. We recommend that the FIG initiates the necessary procedures that this apparatus may be used at future international events. »*

##### 4.2 Testing by an FIG recognised Testing Institute

After the successful practical test by an FIG member federation, the apparatus must be announced at the FIG Secretary General to be tested by one of the FIG's recognised Testing Institutes. For contact persons and addresses see Appendix 2).

The Testing Institute informs the apparatus manufacturer and the FIG in writing, when the apparatus will be tested.

The Testing Institute tests the apparatus following the norms and testing procedures and prepares and submits a test report on behalf of the FIG and the apparatus manufacturer. All costs in connection with the testing (transport and testing fee) are the responsibility of the apparatus manufacturer and have to be paid prior to the tests. (Testing fees see Appendix 4).

For equipment with no existing test procedures the testing is done by the responsible Technical Committee after presentation of the confirmation according to 4.1. All costs are the responsibility of the apparatus manufacturer. The testing shall be announced to the FIG Secretary General.

III
01.01.2009
5

---

### 4.3 Recognition of the FIG Statutes, Rules and Regulations

#### Applicable law and arbitration

##### Code of Auto discipline

Apparatus manufacturers who wish an FIG Certificate have to confirm in writing, that they recognise and strictly follow the FIG Statutes, Rules and Regulations.

For their relationship with the FIG, the Testing Institutes, FIG's member federations, the Continental Unions and the organising committees, the apparatus manufacturer must accept to be governed by Swiss law and in case of disputes, to resolve such disputes to the exclusion of the ordinary courts by arbitration.

The following declaration must be made and signed:

*«We herewith confirm unequivocally to respect and strictly follow the FIG Statutes, Technical Regulations, Code of Points, Apparatus Norms including the Code of Auto discipline and the Rules for Advertising and Publicity. This commitment is valid as long as we have a valid Certificate. »*

*«All disputes arising out of or in connection with the Apparatus Norms, the testing and/or certification of our apparatus and in the relationship with the FIG, or one of their recognised Testing Institutes, Member Federations or Organising Committees shall be resolved, to the exclusion of the ordinary courts by an Arbitration Tribunal constituted in accordance with the Statutes and Regulations of the Court of Arbitration of Sport in Lausanne, Switzerland. We hereby undertake to comply with the said Statutes and Regulation, and to enforce in good faith the award to be rendered. The decision of the Arbitration Tribunal shall be final and binding on the parties.»*

### 4.4 Issuing of FIG Certificates

The FIG Certificate will be issued by the Secretary General, provided the following conditions are met:

- The confirmation/recommendation from a member federation concerning the practical test (see 4.1).
- A positive test report from one of the FIG recognised Testing Institutes.
- Payment of the test fee and the Certificate fee.
- Confirmation / declaration from the manufacturer to recognise the FIG Statutes, Rules and Regulations and confirmation concerning applicable law and arbitration

III
01.01.2009
6

---

## 5. Testing fees of the FIG recognised Testing Institutes

The testing fees must be approved by the FIG and must be identical at all FIG recognised Testing Institutes. The testing fees valid at this time are published in Appendix 4.

The Testing Institutes invoice the Apparatus Manufacturer directly with the testing fees and taxes and must be prepaid.

## 6. Fee for the Certificate

The fee to be paid to the FIG to obtain a Certificate and the attached rights are listed in Part III, § 18 and § 3.

This fee is decided by the Executive Committee and may be adjusted every two years if necessary.

This fee must be paid by the Apparatus Manufactures in advance to the FIG.

## 7. FIG Diploma

Manufacturers, who are in possession of 12 or more valid Certificates, receive a FIG Diploma free of charge. The Diploma is valid as long as the manufacturer has 12 or more valid Certificates.

The FIG Diploma gives the apparatus manufacturer the following additional rights:

- The right to have two VIP accreditations to the official FIG Competitions
- The right to attend the FIG Congress, Council, Gala and Symposium
- The right to be a member of the FIG Apparatus Commission (3 partners at the time, rotation system)
- The right to bear the designation «Official FIG Partner» and to use this on his letter head and promotional material.
- The right, to use the FIG Logo on his letter head and catalogue. The directives (Appendix 1) must be followed.
- A free advertisement (1 x 1/1 page, in colour) in World of Gymnastics every second year.
- A free advertisement in the FIG Bulletin (1 x 1/1 page, black and white) every second year.
- To be mentioned in the list of the Official FIG Partners and official Sponsors, this is published in every Bulletin, in the Directory and on the FIG website.
- The publication of the manufacturer's logo in a composite page together with the official FIG sponsors in every issue of World of Gymnastics.
- A free advertisement (1/1 page, black and white) in the respective Code of Points

III
01.01.2009
7

## 8. Reward for the suppliers of World Championships and World Cup Finals

Apparatus manufacturers who have supplied the apparatus for the World Championships or the World Cup Final alone or with a maximum of one other manufacturer may request a confirmation from the FIG as «Official Supplier of the «World Championships XXX» or of the «World Cup Final XXX». This confirmation may be used for publicity purposes, following the respective Directives of the FIG, (see Appendix .1)

## 9. Renewal of Certificates

After the period of validity a Certificate may be prolonged for two years by paying the fee without testing, provided the norms and/or testing procedures for the respective apparatus have not changed in the meantime and that the apparatus has not lead to any complaints during the validity of the Certificate.

If the construction of the apparatus or the functional properties have changed, the apparatus has to undergo a practical test (see 4.1) as well as by a Testing Institute (see 4.2).

In case of small modifications which do not affect the functional properties or would not lead to a different test results, the FIG may dispense the apparatus manufacturer from testing. In cases of doubt, the President of the Apparatus Commission takes a final decision in cooperation with the concerned Technical President and the Secretary General.

To renew a certificate the apparatus manufacturer must send a request to the FIG – secretariat. This request must include the following three statements:

*“We confirm that the construction of the apparatus and the functional properties have not changed since the last successful test!”*

*“We confirm that the materials used are the same and have the same functional properties as those used for the last successful test!”*

*“We confirm that our apparatus has been adapted to the apparatus norms valid today!”*

The FIG may require a re-test or refuse the prolongation.

## 10. New Apparatus, Modified Apparatus, New Developments

Those are defined as follows:

- New apparatus which are not included in the Apparatus Norms
- Apparatus which are listed in the Apparatus Norms, but which have been significantly modified in their form, functional properties or development

Before the manufacturer constructs a prototype, the FIG recommends that the President of the Apparatus Commission and/or the respective TC President be contacted to find out if such a new apparatus is desired.

If this is confirmed, a prototype can be constructed and presented to the FIG.

Upon recommendation of the respective TC and the Apparatus Commission, the Executive Committee may decide on a general practical test. For such a test, the EC invites manufacturers to produce prototypes and to have those tested at the same time in 4-5 training centres chosen by the FIG. The costs are the responsibility of the apparatus manufacturers interested in the project. After analyses of the test results the Apparatus Commission - in cooperation with the respective TC and the other FIG Commissions - makes the necessary proposals to the EC for the further procedure regarding the possible introduction of the new apparatus.

III
01.01.2009
8

---

## 11. Publication of the FIG Certificates and Diplomas

The FIG regularly publishes a list of the valid Certificates and Diplomas including the period of validity.

## 12. FIG Sticker «FIG APPROVED»

Apparatus manufacturers who are in possession of a valid FIG Certificate have the right to stick or print the « FIG Approved » sticker on the respective apparatus. The sticker can be received from the FIG free of charge. «FIG Approved» is also available by electronic support. For colours and size see Appendix 1.

Upon written approval by the FIG Secretary General, the Sticker “FIG-Approved” can also be used for apparatuses which have no certificate and where no test is required i.e. supplementary mats, spotter mats, measuring table for RG-Apparatus etc. The written approval of the Secretary General also allows the manufacturer to use the term “FIG-Approved” for the publicity and offers of the above mentioned kind of apparatuses.

Each written approval issued by the Secretary General is valid for two years and costs 25% of the current fees for FIG Certificates as per point III, p. 17 of these regulations per apparatus.

These written approvals cannot be considered as a “certificate” in the spirit of these rules.

It is not possible to issue such an approval for manufacturers who have no valid certificate.

## 13. Control of Apparatus at the competitions Re-testing of apparatus by the FIG at the Testing Institute

At the official events of the FIG, as well as at the Olympic Games and World Games, the apparatus are officially controlled on site. This control mainly consists of checking the measurements, making sure that the apparatus used at the competition is identical to the tested one, as well as a control of the layout, safety area and matting. The apparatus manufacturer is responsible that those delivered apparatus are 100% identical to the one tested in respect of the material used as well as the construction. The apparatus manufacturers are fully responsible that the norms are strictly respected; the correct setting up of the apparatus is the responsibility of the organising committee.

The FIG has and reserves the right to re-test apparatus before, during and after an event at the nearest recognised Testing Institute. In case the testing report is positive, all costs are at the charge of the FIG. In case the report is negative, the costs are at the charge of the apparatus manufacturer. Furthermore the validity of the Certificate is immediately withdrawn. The Executive Committee decides about the duration of a ban against the respective manufacturer. Afterwards, the manufacturer may apply Certificate to be issued by the FIG (following 4.4).

III
01.01.2009
9

---

#### **14. FIG recognised Testing Institutes**

The following Testing Institutes are recognised by the FIG at this time:

- Albert Ludwigs' University of Freiburg (GER)
- Tokyo Institute of Technology (JPN)

For addresses, contact person, delivery addresses etc. see Appendix 1

All Testing Institutes charge the same testing fee. (See Appendix 4)  
The testing fees must be approved by the FIG.

The Testing Institutes are absolutely neutral and must strictly follow the FIG testing procedures. Testing equipment and conditions must be equal at all Testing Institutes.

It is the goal that all Testing Institutes are able to test all apparatus.

Appendix 3 lists which institute can test which apparatus.

Part IV of the Apparatus Norms also gives the necessary information about how many apparatus, m2 or m of the respective apparatus must be supplied for testing purposes.

#### **15. Publicity and apparatus manufacturer's logo on the apparatus**

See FIG Rules for Advertising and Publicity.

#### **16. Waiver of Liability**

With these Apparatus Norms, the FIG and its member federations, as well as the Testing Institutes are in no way responsible for the apparatus. The FIG, its member federations and the Testing Institutes waive all liability in connection with the use of apparatus described in these Apparatus Norms.

<b>III</b>
<b>01.01.2009</b>
<b>10</b>

---

**17. Current Fees for FIG Certificates**

The following fees for Certificates are applied:

The fee to be paid to issue a Certificate for the first time or to renew a Certificate depends on the number of valid Certificates a manufacturer already has

<b>Number of Certificates held</b>	<b>Fee in EURO per Certificate</b>
1	5'000
2 - 3	4'000
4 - 5	3'000
6 - 7	2'000
8 - 9	1'000
10 - 11	800
12 and more	600

**18. Code of Auto discipline**

A "Code of Auto discipline" has been elaborated by the Apparatus Commission and approved by the FIG Executive Committee in order to determine the rules, concerning the manufactures relations with the FIG and between themselves.

The rules envisaged in the Auto discipline Code are applied automatically to each infraction of the Apparatus Norms in force.

See Appendix 5

III
01.01.2006
11

---

**DIRECTIVES / REGULATIONS FOR THE USE OF  
OFFICIAL FIG DESIGNATIONS AND LOGOS**

**1. GENERAL PRINCIPLES**

- 1.1. The designations and logotypes/logos which are presented in this document are property of the *Fédération Internationale de Gymnastique (FIG)*. Their use requires the FIG's authorization. Any illegal use or non-conformity with these directives will be prosecuted and results in the withdrawal of the certificate or diploma.
- 1.2. The **acquisition** conditions for these designations which are reserved for the FIG partners are included in the brochure "Apparatus Norms" published by the FIG.
- 1.3. The **use** of these designations and logotypes/logos which are reserved for the FIG partners is prescribed in this appendix.
- 1.4. The general graphic prescriptions are defined in the FIG Graphics Chart.
- 1.5. The graphic prescriptions reserved for the use of the FIG apparatus manufacturers are included in this appendix.
- 1.6. The use of any designation or logotype/logos other than those mentioned in this appendix is strictly prohibited.
- 1.7. Any other reference to "FIG", use of the abbreviation "FIG" (or "Fédération Internationale de Gymnastique" in any language) as well as wordings such as "following FIG Norms", "in the process to be tested" etc. are strictly prohibited.

**2. DEFINITIONS**

These directives regulate the different rights of the three apparatus manufacturer categories as follows:

- 2.1 Holder of the "**FIG-Certificate**"
- 2.2 Holder of the "**FIG-Diploma**"
- 2.3 Holder of an FIG confirmation as "**Official Supplier of the World Championships**" or as "**Official Supplier of the World Cup Final**"

III
01.01.2006
12

## Appendix 1

### 3. HOLDER OF THE FIG-CERTIFICATE

The holder of the " FIG Certificate" may use the logotype "**FIG Approved**" respecting the following conditions:

- 3.1 The logotype may only and exclusively be associated with only one element respectively one single article, apparatus or accessory duly certified by the FIG.
- 3.2 It may be used on an article respectively an apparatus or an accessory itself or it may be integrated in any type of advertising or publicity but only **in direct connection or relation** with the respective certified apparatus. The logotype may also appear in a description of the certified apparatus (advertisement, publicity leaflet etc.)
- 3.3 It may not be used as an isolated element, separate from the apparatus.**
- 3.4 Consequently it may not appear on letter heads, cover pages of catalogues, or in editorial articles with advertising purposes, nor in any other institutional documents containing general information.

#### 3.5. Graphics

##### 3.5.1. Logotype FIG Approved: (respect the size as per 3.6.1)



##### 3.5.2. Colours

According to the range defined by the FIG Graphics Chart.

- **Black**
- **Blue Pantone 3005 U**
- **Red Warm red CV**

#### 3.6. Use and size / Maximum dimensions

##### 3.6.1. On printed matters

<b>Formats:</b>	A5	14.8 x 21.0 cm	ø 08 mm max.
	A4	21.0 x 29.7 cm	ø 12 mm max.
	A3	29.7 x 42.0 cm	ø 18 mm max.
	A2	42.0 x 59.4 cm	ø 35 mm max.
	A1	59.4 x 84.1 cm	ø 60 mm max.

III
01.01.2006
13

### 3.6.2. On the apparatus

The logotype "**FIG Approved**" may only be applied to the support surfaces (supports, legs of apparatus) of the apparatus. Maximum diameter is 35 mm.

On the floor and on the mats the logotype may appear in one of the four corners with a maximum distance of 5 cm to the corner or on the side of the floor/mat with the exception of the surfaces which are reserved for advertising purposes as defined in the "FIG Rules for Advertising and Publicity ". Maximum diameter is 35 mm.

On the apparatus for rhythmic gymnastics the logotype/sticker "**FIG Approved**" may appear in the following way:

- Only on the bottom side of the clubs;
- On the surface of the ball, Ø maximum 25 mm.;
- On the ribbon, maximum 5 cm from the point where the ribbon is fixed to the stick, Ø max. 25 mm.

## 4. HOLDER OF THE FIG DIPLOMA

- 4.1. The right to use the designation "**Official FIG Partner**" subject to article 1.5 of the "FIG Rules for Advertising and Publicity".
- 4.2. The right to use the **FIG Logo** for advertising purposes only, strictly respecting the FIG Graphics Chart.

In addition to the rights listed in chapter 3, the holder of a FIG Diploma obtains:

### FIG Logo:



- 4.3. The title "Official FIG Partner" and the FIG logotype may by no means be used directly attached to or with a product but only with the **company name or identity** of the holder of the FIG Diploma. (e.g.: letter heads, envelopes, cover pages of catalogues, various kinds of printed material, newsletters, "give aways" etc.)

III
01.01.2006
14

5. **HOLDER OF AN FIG CONFIRMATION AS  
"OFFICIAL SUPPLIER FOR THE WORLD CHAMPIONSHIPS" OR AS  
"OFFICIAL SUPPLIER OF THE WORLD CUP FINAL"**

5.1. The apparatus manufacturer who has been duly confirmed by the FIG may use the designation

**"Official Supplier of the World Championships X"**  
**"Official Supplier of the World Cup Final Y"**

5.2. The use of the above-mentioned designation (for advertising purposes only) can only be associated with the supplied apparatus and also with the company name of the manufacturer. (e.g.: letter heads, envelopes, cover pages of catalogues, various kinds of printed material, newsletters, "give aways" etc.)

5.3. The above-mentioned designation may be used together with the FIG logotype according to the regulations of the FIG Graphics Chart and within the following dimensions:

5.4. <u>Formats:</u>	A5	14.8 x 21.0 cm	Ø 8 mm max.
	A4	21.0 x 29.7 cm	Ø 12 mm max.
	A3	29.7 x 42.0 cm	Ø 18 mm max.
	A2	42.0 x 59.4 cm	Ø 35 mm max.
	A1	59.4 x 84.1 cm	Ø 60 mm max.

### **RECOMMENDATION**

We strongly recommend that the holder of a certificate or a diploma should send his drafts of all printed matters to the FIG to be proof-read prior to printing.

III
01.01.2006
15

---

**FIG RECOGNISED TESTING INSTITUTES**

**ADDRESSES AND CONTACT PERSONS**

**Albert Ludwigs University**

Institute of Sport and Sport Science  
Schwarzwaldstrasse 175  
D-79117 Freiburg i. Br.  
Germany

Fax +49 761 203 4555  
Phone +49 761 203 4554  
e-mail [gymlab@sport.uni-freiburg.de](mailto:gymlab@sport.uni-freiburg.de)

Contact Person Ludwig Schweizer

**Tokyo Institute of Technology**

Faculty of Engineering  
Department of Architecture and Building Engineering  
FIG Norm Testing Laboratory (Ono Lab.)  
2-12-1 O-okayama  
Meguro-ku  
Tokyo 152-8552  
Japan

Fax +81 3 5734 3164  
Phone +81 3 5734 3164  
E-mail [mikami@mei.titech.ac.jp](mailto:mikami@mei.titech.ac.jp)

Contact Person Takamasa Mikami

## FIG RECOGNISED TESTING INSTITUTES

- What can be tested where? -

III
01.01.2011
16

<b>MAG</b>	<b>Apparatus</b>	<b>Code</b>	<b>Test Procedure</b>	<b>Frbg</b>	<b>Tokyo</b>
	Floor	MAG1	Complete Test	√	√
	Pommel Horse	MAG2	Complete Test	√	√
		MAG2-1	<i>Shock Absorption</i>	√	√
		MAG2-2	<i>Top Friction of Horse Body</i>	√	√
		MAG2-3	<b>Pos. Stability of Pommels</b>	√	√
		MAG2-4	<i>Friction of Pommels</i>	√	√
	Rings	MAG3	Complete Test	√	√
	Vaulting Table	MAG4	Complete Test	√	√
	Parallel Bars	MAG5	Complete Test	√	√
		MAG5-1	<b>Static traction stress</b>	√	√
		MAG5-2	<i>Stress by pendulum swing</i>	√	√
		MAG5-3	<i>Oscillation damping</i>	√	√
		MAG5-4	<i>Lateral stability</i>	√	√
	Horizontal bar	MAG6	Complete Test	√	√
		MAG6-1	<b>Static traction stress</b>	√	√
		MAG6-2	<i>Stress by pendulum swing</i>	√	√
		MAG6-3	<i>Oscillation damping</i>	√	√
	Landing Mat 20cm	MAG11	Complete Test	√	√
	Landing Mat 10cm	MAG12	Complete Test	√	√
	Vaulting Board	MAG14	Complete Test	√	√
<b>WAG</b>	<b>Apparatus</b>	<b>Code</b>	<b>Test Procedure</b>	<b>Frbg</b>	<b>Tokyo</b>
	Vaulting Table	WAG1	Complete Test (see MAG4)	√	√
	Uneven Bars	WAG2	Complete Test	√	√
		WAG2-1	<b>Static traction stress</b>	√	√
		WAG2-2	<i>Stress by pendulum swing</i>	√	√
		WAG2-3	<i>Oscillation damping</i>	√	√
	Balance Beam	WAG3	Complete Test	√	√
		WAG3-1	<b>Shock Absorption</b>	√	√
		WAG3-2	<i>Top Friction</i>	√	√
	Floor	WAG4	Complete Test (see MAG1)	√	√
	Landing Mat 20cm	WAG11	Complete Test (see MAG11)	√	√
	Vaulting Board	WAG14	Complete Test (see MAG14)	√	√
<b>RG</b>	<b>Apparatus</b>	<b>Code</b>	<b>Test Procedure</b>	<b>Frbg</b>	<b>Tokyo</b>
	Floor	RG1	Complete Test	√	√
		RG1-1	<i>Shock Absorption</i>	√	√
		RG1-2	<i>Static stiffness</i>	√	√
		RG1-3	<b>Top Friction</b>	√	√
<b>AER</b>	<b>Apparatus</b>	<b>Code</b>	<b>Test Procedure</b>	<b>Frbg</b>	<b>Tokyo</b>
	Floor	AER1	Complete Test	√	√
<b>TRA</b>	<b>Apparatus</b>	<b>Code</b>	<b>Test Procedure</b>	<b>Frbg</b>	<b>Tokyo</b>
	Trampoline	TRA1	Complete Test	√	√
	Tumbling Track	TRA3	Complete Test	√	√
		TRA3-1	<i>Shock Absorption</i>	√	√
		TRA3-2	<i>Top Friction</i>	√	√
	Landing Mat 20cm	TRA11	Complete Test	√	√
	Vaulting Board	TRA14	Complete Test (see MAG14)	√	√
	TMD	TRA15	Complete Test	√	√
<b>ACRO</b>	<b>Apparatus</b>	<b>Code</b>	<b>Test Procedure</b>	<b>Frbg</b>	<b>Tokyo</b>
	Floor	ACRO1	Complete Test (see MAG1)	√	√
	Landing Mat 20cm	ACRO11	Complete Test (see MAG11)	√	√

**TESTING FEES OF THE FIG  
RECOGNISED TESTING INSTITUTES**

<b>III</b>
01.01.2011
<b>17</b>

<b>MAG</b>	<b>Apparatus</b>	<b>Code</b>	<b>Test Procedure</b>	<b>Charge</b>
	Floor	MAG1		€ 2000.-
	Pommel Horse	MAG2	Complete Test	€ 3600.-
		MAG2-1	<i>Shock Absorption</i>	€ 2000.-
		MAG2-2	<i>Top Friction of Horse Body</i>	€ 600.-
		MAG2-3	<i>Pos. Stability of Pommels</i>	€ 400.-
		MAG2-4	<i>Friction of Pommels</i>	€ 600.-
	Rings	MAG3		€ 2000.-
	Vaulting Table	MAG4		€ 3600.-
	Parallel Bars	MAG5	Complete Test	€ 5200.-
		MAG5-1	<i>Static traction stress</i>	€ 600.-
		MAG5-2	<i>Stress by pendulum swing</i>	€ 2000.-
		MAG5-3	<i>Oscillation damping</i>	€ 2000.-
		MAG5-4	<i>Lateral stability</i>	€ 600.-
	Horizontal Bar	MAG6	Complete Test	€ 4000.-
		MAG6-1	<i>Static traction stress</i>	€ 600.-
		MAG6-2	<i>Stress by pendulum swing</i>	€ 1700.-
		MAG6-3	<i>Oscillation damping</i>	€ 1700.-
	Landing Mat 20cm	MAG11		€ 2000.-
	Landing Mat 10cm	MAG12		€ 2000.-
	Vaulting Board	MAG14		€ 3000.-
<b>WAG</b>	<b>Apparatus</b>	<b>Code</b>	<b>Test Procedure</b>	<b>Charge</b>
	Vaulting Table	WAG1		See MAG4
	Uneven Bars	WAG2	Complete Test	€ 4800.-
		WAG2-1	<i>Static traction stress</i>	€ 800.-
		WAG2-2	<i>Stress by pendulum swing</i>	€ 2000.-
		WAG2-3	<i>Oscillation damping</i>	€ 2000.-
	Balance Beam	WAG3	Complete Test	€ 2600.-
		WAG3-1	<i>Shock Absorption</i>	€ 2000.-
		WAG3-2	<i>Top Friction</i>	€ 600.-
	Floor	WAG4		See MAG1
	Landing Mat 20cm	WAG11		See MAG11
	Vaulting Board	WAG14		See MAG14
<b>RG</b>	<b>Apparatus</b>	<b>Code</b>	<b>Test Procedure</b>	<b>Charge</b>
	Floor	RG1	Complete Test	€ 4000.-
		RG1-1	<i>Shock Absorption</i>	€ 2000.-
		RG1-2	<i>Static stiffness</i>	€ 400.-
		RG1-3	<i>Top Friction</i>	€ 1600.-
<b>AER</b>	<b>Apparatus</b>	<b>Code</b>	<b>Test Procedure</b>	<b>Charge</b>
	Floor	AER1		€ 2000.-
<b>TRA</b>	<b>Apparatus</b>	<b>Code</b>	<b>Test Procedure</b>	<b>Charge</b>
	Trampoline	TRA1		€ 4000.-
	Tumbling Track	TRA3	Complete Test	€ 3400.-
		TRA3-1	<i>Shock Absorption</i>	€ 2400.-
		TRA3-2	<i>Top Friction</i>	€ 1000.-
	Landing Mat 20cm	TRA11		See MAG11
	Vaulting Board	TRA14		See MAG14
	TMD	TRA15	Complete Test	€ 2000.-
<b>ACRO</b>	<b>Apparatus</b>	<b>Code</b>	<b>Test Procedure</b>	<b>Charge</b>
	Floor	ACRO1		See MAG1
	Landing Mat 20cm	ACRO11		See MAG11

Fees without additional Value added tax according to the Country of Test (actually: Germany 19%)

**TESTING FEES OF THE FIG  
RECOGNISED TESTING INSTITUTES**

<b>III</b>
01.01.2011
<b>18</b>

Firms can obtain a discount on the testing fees provided that they own 4 or more certificates from the FIG. The percentage of discount depends on the number of certificates:

Number of Certificates	Discount
4 - 5	10%
6 - 7	20%
8 - 9	30%
10 - 11	40%
12+	50%

<b>III</b>
<b>21.05.2009</b>
<b>19</b>

## **I General**

- The present code has been elaborated by the Apparatus Commission and approved by the FIG Executive Committee in order to determine the rules, concerning the manufactures relations with the FIG and between themselves. The following should also be taken into account: The Technical Regulations, the manual «FIG Apparatus Norm, Part I-IV», the Code of Ethics and the Advertising and Publicity Rules.
- The rules envisaged in the Auto discipline Code are applied automatically to each infraction of the rules in force. Modifications to the present code may only be made by the FIG Executive Committee, upon request of the TCs, the Apparatus Commission or the FIG Partners.

## **II Rules and Criteria for Partners**

- Partners must have 12 different FIG Certificates.
- Supplied at least one official FIG World or Continental Championships.
- Elaborate a research program for the development and security of apparatus
- Contribute to the development of gymnastics in the world
- Ensure the financial health of company.

## **III The Rights of the FIG Partners**

- The right to have two VIP accreditations to the official FIG Competitions.
- The right to assist at the FIG Congress, Council, Gala and Symposium
- The right to be a member of the FIG Apparatus Commission (2 partners at the time, rotation system)
- The right to bear the designation «Official FIG Partner» and to use this on his letter head and promotional material.
- The right, to use the FIG Logo on his letter head and catalogue. The directives (Appendix 1) must be followed.
- A free advertisement (1 x 1/1 page, in colour) in World of Gymnastics every second year.
- A free advertisement in the FIG Bulletin (1 x 1/1 page, black and white) every second year.
- To be mentioned in the list of the Official FIG Partners and official Sponsors, this is published in every Bulletin, in the Directory and on the FIG website.
- The publication of the manufacturer's logo in a composite page together with the official FIG sponsors in every issue of World of Gymnastics.
- A free advertisement (1/1 page, black and white) in the respective Code of Points

## **IV List of possible infractions against the FIG Apparatus Norms and Other FIG Rules and Regulations and Sanctions applied by the FIG**

### **General Infractions:**

- Selling and/or offering certified apparatus without a valid certificate (certificate expired) (1<sup>st</sup> offence)  
*Written warning +*

III
21.05.2009
20

- Rectify the offer (notification of the customer(s) by the manufacturer with copy to the FIG +  
Fine of Euro 2,000.-*
- Same as above but 2<sup>nd</sup> offence.  
*Rectify the offer (notification of the customer by FIG) +  
Fine of Euro 5,000.-*
  - Selling and/or offering certified apparatus without a valid certificate (certificate not yet or never issued)  
*Written warning +  
Rectify his offer (notification of the customer(s) with copy to FIG)+  
FIG may inform client(s) +  
Fine of Euro 2,000. - +  
Publication of the sanction*
  - Same as above, but 2<sup>nd</sup> offence.  
*Written warning +  
Rectify his offer (notification of the customer(s))+  
FIG informs client(s) +  
Fine of Euro 5,000. - +  
Publication of the sanction +  
If FIG Partner, loss of status for 1 year*
  - Testing an apparatus and selling and/or deliberately offering a different apparatus or construction or modified apparatus than the tested prototype.  
*Withdrawal of the respective certificate for 1 year +  
New test required +  
Fine of Euro 5'000.- +  
Publication of the sanction.*
  - Same as above, but 2<sup>nd</sup> offence.  
*Withdrawal of certificates for 2 years +  
New tests required +  
Fine of Euro 10,000.- +  
Publication of the sanction.*
  - Wrong statements to FIG concerning "unchanged" equipment  
*Withdrawal of the respective certificate for one year +  
New test required +  
Fine of Euro 5,000.- +  
Publication of the sanction.*
  - Same as above, but 2<sup>nd</sup> offence.  
*Withdrawal of certificates for 3 years +  
New tests required +  
Fine of Euro 10,000.- +  
Publication of the sanction.*

III
21.05.2009
21

### Infractions committed at FIG events

- Selling, renting, sponsoring, offering, delivering, installing etc, not certified apparatus (not certified at all, expired certificate or different apparatus from the tested one) for use at an FIG event and events where FIG Certified equipment is requested.  
*Immediate rectification whenever possible +  
Withdrawal of the respective certificate for one year +  
New test required +  
Fine of Euro 3,000.- +  
Publication of the sanction.*
- Same as above but 2<sup>nd</sup> offence.  
*Immediate rectification whenever possible +  
Withdrawal of certificates for 2 years +  
New tests required +  
Fine of Euro 6,000.- +  
Publication of the sanction.*
- Lack of quality of apparatus used at FIG events  
*FIG may take the apparatus and send it for testing*
- Lack of quality of apparatus used at FIG events (Apparatus does not pass the test after an event)  
*Withdrawal of the respective certificate for one year +  
New test required +  
Fine of Euro 2,000.- +  
Publication of the sanction.*
- Same as above but 2<sup>nd</sup> offence  
*Withdrawal of the respective certificate for 2 years +  
New test required +  
Fine of Euro 5,000.- +  
Publication of the sanction.*
- Infraction against size of Manufacturers Logo and/or Advertising on apparatus  
*Immediate rectification +  
Written warning*
- Same as above but 2<sup>nd</sup> offence  
*Immediate rectification +  
Written warning +  
Fine of Euro 500.-*
- Infraction against placement of Manufacturers Logo on apparatus  
*Immediate rectification+  
Written warning*
- Same as above but 2<sup>nd</sup> offence  
*Immediate rectification +  
Written warning +  
Fine of Euro 500.-*

III
21.05.2009
22

- Repeated infractions against size and / or placement of Manufacturers Logo (3<sup>rd</sup> and more cases)  
*Immediate rectification +  
Fine of Euro 5,000.-*
- Placement of Manufacturers Logo or anything else in the Advertising Area.  
*Immediate rectification +  
Written warning*
- Same as above but 2<sup>nd</sup> offence  
*Immediate rectification +  
Written warning +  
Fine of Euro 1,000.-*
- Distribution of presents, PR, or other advertising and publicity items to competitors and or officials (FIG or Member Federations) without written approval of FIG at FIG events.  
*Immediate stop of action +  
Written warning*
- Same as above but 2<sup>nd</sup> offence  
*Immediate stop of action +  
Written warning +  
Fine of Euro 2,000.-*
- Placing of advertising and publicity in the competition hall other than the standard advertising boards as foreseen in the Rules for Advertising and Publicity without the written approval of FIG  
*Immediate stop of action and rectification +  
Written warning*
- Same as above but 2<sup>nd</sup> offence  
*Immediate stop of action and rectification +  
Written warning +  
Fine of Euro 1,000.-*
- Other infractions against the Rules for Advertising and Publicity  
*Similar sanctions as mentioned above, depending on the severity of the infraction.*

Catalogues / Publicity / Flyers / Printed Matters / Advertising etc.

- Using the abbreviation FIG in any way for not FIG certified apparatus, suggesting or giving the wrong impression of a relationship with FIG.  
*Immediate stop of action, rectification and notification of the customers with copy to the FIG +  
FIG may notify customer(s) +  
Written warning*
- Same as above, but 2<sup>nd</sup> offence.  
*Immediate stop of action, rectification and notification of the customers  
With copy to the FIG +  
Written warning +*

III
21.05.2009
23

- FIG to notify customers +  
Fine of Euro 5,000.-*
- Using the FIG logo without being an FIG partner  
*Immediate stop of action, rectification and notification of the customers with copy to the FIG +  
Written warning*
  - Same as above, but 2<sup>nd</sup> offence.  
*Immediate stop of action, rectification and notification of the customers with copy to the FIG +  
Written warning +  
Fine of Euro 5,000.-*
  - Using the logo "FIG Approved" for not certified apparatus.  
*Immediate stop of action, rectification and notification of the customers with copy to the FIG +  
Written warning*
  - Same as above, but 2<sup>nd</sup> offence.  
*Immediate stop of action, rectification and notification of the customers with copy to the FIG +  
Written warning +  
Fine of Euro 5,000.-*
  - Not respecting the size of the FIG logo or FIG Approved logo.  
*Immediate stop of action and rectification +  
Written warning*
  - Same as above, but 2<sup>nd</sup> offence.  
*Immediate stop of action and rectification+  
Written warning+  
Fine of Euro 500.-*
  - Repeated offence as mentioned above.  
(3 and more cases)  
*Immediate stop of action and rectification+  
Written warning +  
Fine of Euro 2,000.--*
  - Not using the FIG Approved logo directly attached to the respective product, thus giving the impression that other not certified products could also be FIG Approved.  
*Immediate stop of action, rectification and notification of the customers with copy to the FIG +  
Written warning*
  - Same as above, but 2<sup>nd</sup> offence.  
*Immediate stop of action, rectification and notification of the customers with copy to the FIG +  
Written warning +  
Fine of Euro 5,000.-*

III
21.05.2009
24

- Infractions of clients (retailers) of an FIG Manufacturer or FIG Partner misusing the word FIG, the FIG Logo or the logo FIG Approved  
*Immediate stop of action, rectification and notification of the customers with copy to the FIG +*  
*Written warning +*  
*FIG informs the FIG Manufacturer*
- Same as above, but 2<sup>nd</sup> offence or not following FIG's requests at the time of the 1<sup>st</sup> Offence,  
*Immediate stop of action, rectification and notification of the customers with copy to the FIG +*  
*Written warning+*  
*Fine of Euro 1,000.- +*  
*FIG requests FIG Manufacturer to no longer sell their products to the respective client.*  
*Manufacturer's Certificate will be withdrawn by FIG if the problem remains.*
- Giving the impression of FIG approval or certification by using misleading wording such as e.g. "meets FIG specs", or "following FIG rules" or similar.  
*Immediate stop of action, rectification and notification of the customers with copy to the FIG +*  
*Written warning*
- Same as above, but 2<sup>nd</sup> offence.  
*Immediate stop of action, rectification and notification of the customers with copy to the FIG +*  
*Written warning +*  
*Fine of Euro 1,000.-*
- Reference to "old" and/or no longer valid certificates or former Diplomas  
*Immediate stop of action, rectification and notification of the customers with copy to the FIG +*  
*Written warning*
- Same as above, but 2<sup>nd</sup> offence.  
*Immediate stop of action, rectification and notification of the customers with copy to the FIG +*  
*Written warning +*  
*Fine of Euro 5'000.- +*  
*Possible withdrawal of other certificates*
- Using falsified certificates  
*Immediate stop of action, rectification and notification of the customers with copy to the FIG +*  
*FIG may inform customer(s)*  
*Fine of Euro 10,000.-*  
*Publication of the sanction*
- Same as above, but 2<sup>nd</sup> offence.  
*Immediate stop of action, rectification and notification of the customers +*  
*Fine of Euro 20,000.- +*  
*Withdrawal of all Certificates for a time to be defined by FIG.*  
*Publication of the sanction*

<b>III</b>
<b>21.05.2009</b>
<b>25</b>

- NOT FOLLOWING OR RESPECTING SANCTIONS  
*Action and further sanctions to be taken at the discretion of FIG.*
- Infractions not listed above  
*The FIG will take action and sanctions as deemed necessary at its discretion, following in principle similar cases listed above*

In addition to all the fines and sanctions listed above, the FIG reserves the right to take additional action as deemed necessary.

#### **V. Procedure in case of Infractions and Sanctions**

Infractions may be observed by all concerned (Apparatus Manufacturers, FIG Officials and third parties). Such observations must be given in writing to the FIG Secretary General.

The Secretary General will then take the necessary actions.

Written warnings are treated and decided by the Secretary General.

Immediate actions and decisions for infractions committed during FIG events are taken by the Secretary General and in his absence by his representative or the President of the Superior Jury. If he deems necessary, he will then forward the case to the FIG Disciplinary Commission for further action.

The Secretary General will report all warnings to the Apparatus Commission.

Offences with fines are treated by the FIG Disciplinary Commission.

The FIG Secretary General will keep a list of all offences warnings and sanctions.

This list will include the date of the offence.

The 1<sup>st</sup> offences will be considered as deleted after the following time period:

- Written warnings and offences with up to and including Euro 1,000.-  
after 1 Olympic Cycle.
- Offences with fines up to and including Euro 5,000.- after 2 Olympic cycles
- Offences with fines over Euro 5,000.- after 3 Olympic cycles

All fines will be credited to the FIG Development Fund.

#### **VI. Appeal against Sanctions**

- Warnings decided by the FIG Secretary General:

The Apparatus Manufacturers may make an appeal against decisions of the Secretary General to the FIG Disciplinary Commission.

No further appeal is possible. The decision of the FIG Disciplinary Commission is final.

- Decisions taken by the FIG Secretary General for concerning infractions during an FIG event:

<b>III</b>
<b>21.05.2009</b>
<b>26</b>

The Apparatus Manufacturers may make an appeal against decisions and actions taken by of the Secretary General to the Jury of Appeal of the respective competition.

No further appeal is possible. The decision of the Jury of Appeal is final.

- Sanctions decided by the FIG Disciplinary Commission

The Apparatus Manufacturers may make an appeal against the decision taken by the FIG Disciplinary Commission as follows:

instance of appeal: FIG Appeal Tribunal

Appeals must be made in writing within 21 days and sent to the President of the instance concerned with a copy to the FIG Secretary General.

Depending on the outcome of the appeal, the Disciplinary Commission and the Appeal Tribunal will decide who has to bear the costs.

The procedures and costs for appeals to the Disciplinary Commission and the FIG Appeal Tribunal are ruled in the FIG Code of Discipline.

#### **VII. Rules for the distribution of the Letter of Recognition**

- FIG Letter of Recognition to be given to the official manufactures for the excellence of their work.
- A special FIG diploma will be given to the official supplier of 3 World Championships or World Cup Finals in 2 Olympic cycles.
- A special recognition FIG plate is to be attributed for service rendered to the development of gymnastics in the capacity of FIG partner and for the good relations with the other manufactures.

III
01.01.2011
27

Intermediate Rules re. The validity of new norms and renewal of certificates for the following apparatus:

**Floors for Artistic Gymnastics (MAG 1 and WAG 4)  
and Acrobatic Gymnastics (ACRO 1)**

Please be reminded that for floor testing 4 parts out of 4 complete plates (including connections) with a minimum overall size of: 2000 x 3000 mm must be sent to the testing Institute. (see picture below)

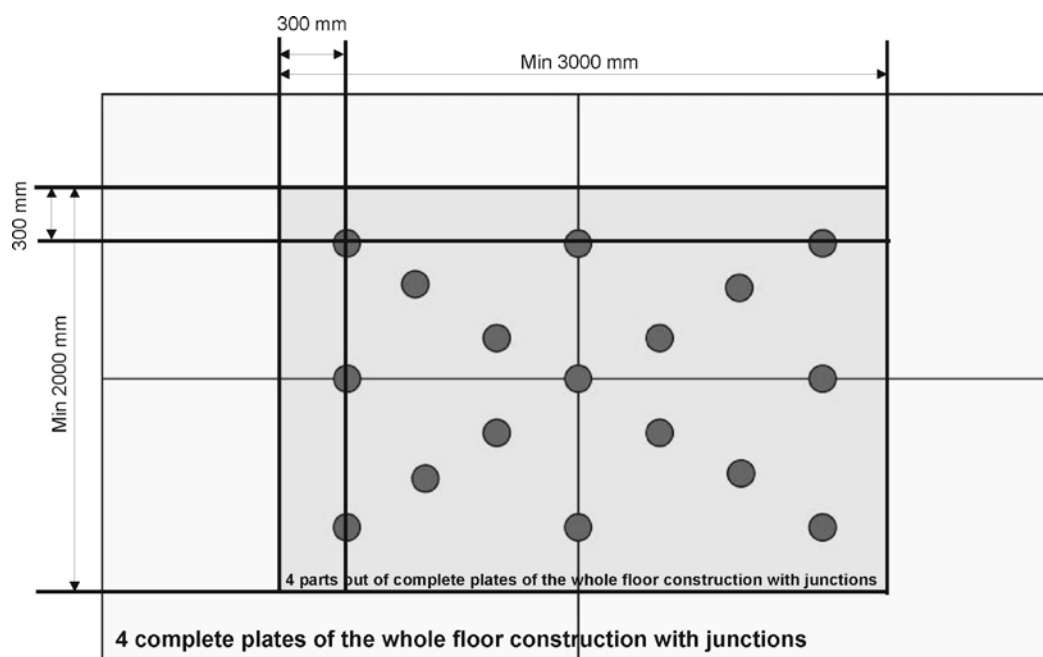

III
01.01.2011
28

### **Tumbling Track (TRA 3)**

The new norm published in these Apparatus Norms whereas the height of the Tumbling Track may be max 30 cm is valid immediately for new Tumbling Tracks.

A transition period until 31<sup>st</sup> December 2011 is granted for Tumbling Tracks which have a valid certificate at this time (26<sup>th</sup> July 2006).

Existing Certificates may therefore be prolonged until max. 31<sup>st</sup> December 2011, but all Tumbling Tracks received for testing after 26<sup>th</sup> July 2006 must fulfil the above mentioned norm.

The new norm published in these Apparatus Norms whereas the width of the Tumbling Track is 200 cm +/- 5 cm is valid immediately for the 2009 World Championships and for all Tumbling Tracks received for testing. Existing Certificates may be prolonged only if the manufacturer in it application certifies that the above mentioned norm is fulfilled.

### **Safety Collar (MAG 15/WAG 15)**

Testing procedures for the Safety Collars will be developed during 2011 and as of 1<sup>st</sup> of January 2013, Safety Collars must have passed a test and have a valid FIG Certificate.

### **Trampoline – Safety Padding (TRA 1)**

The new norm published in these Apparatus Norms regarding safety padding (see 5.1 and 5.3) is valid immediately for new Trampolines, i.e. all trampolines received for testing after 1<sup>st</sup> June 2009 must fulfil the above mentioned norm.

Existing Certificates may be prolonged only if the manufacturer in its application certifies that above mentioned norm is fulfilled.

Only trampolines that meets the above mentioned norm may be used at World Championships and Olympic Games from 2010 and onwards. For all other international competitions, the new norm must be implemented by 1<sup>st</sup> of January 2013.

# PASTORELLI®

Professional sportswear and equipment supplier  
Rhythmic Gymnastics

*... Give voice to your passion*



FIG Official Partner



-  **Equipment**
-  **Accessories**
-  **Cosmetics**
-  **Gadgets**
-  **Leotards**

[www.pastorellisport.com](http://www.pastorellisport.com)

## Impressum

### Edition 2011:

Publisher	Fédération Internationale de Gymnastique
Responsible	<u>FIG - Apparatus Commission (2009 – 2012)</u> Atilla Örsel, President of the Apparatus Commission Nicolae Vieru, FIG Jvan Weber, FIG Ludwig Schweizer, GYMLAB (Vassili Titov)
	Jay Ashmore, AAI 2009 Hiro Hirabayashi, SENOH 2009 Ulrich Spieth, SPIETH Gymnastic 2010-2011 Mike Booth, CONTINENTAL 2010-2011 Jörn Bänfer, BÄNFER 2011
Drawings	Karl - Heinz Schwirtz / Ludwig Schweizer
Translations	FIG Secretariat / GYMLAB – University of Freiburg
©	Fédération Internationale de Gymnastique

Train and compete on the equipment trusted by the  
**Best Gymnasts in the World.**



Official Equipment Supplier  
to NCAA Gymnastics Championships



Official Supplier and Partner



Approved Supplier and Partner

**AAI**®

[www.americanathletic.com](http://www.americanathletic.com)

Women's Apparatus - Men's Apparatus - Rhythmic Floors - Competition and Folding mats - Training Accessories - Motor Development

AAI and design is a registered trademark of Russell Brands, LLC. © 2010 Russell Brands, LLC.

